



200 Proofs Earth is Not a Spinning Ball

By Eric Dubay

AtlanteanConspiracy.com

IFERS.boards.net

200 Proofs Earth is Not a Spinning Ball

by Eric Dubay

1) The horizon always appears perfectly flat 360 degrees around the observer regardless of altitude. All amateur balloon, rocket, plane and drone footage show a completely flat horizon over 20+ miles high. Only NASA and other government “space agencies” show curvature in their fake CGI photos/videos.



2) The horizon always rises to the eye level of the observer as altitude is gained, so you never have to look down to see it. If Earth were in fact a globe, no matter how large, as you ascended the horizon would stay fixed and the observer / camera would have to tilt looking down further and further to see it.

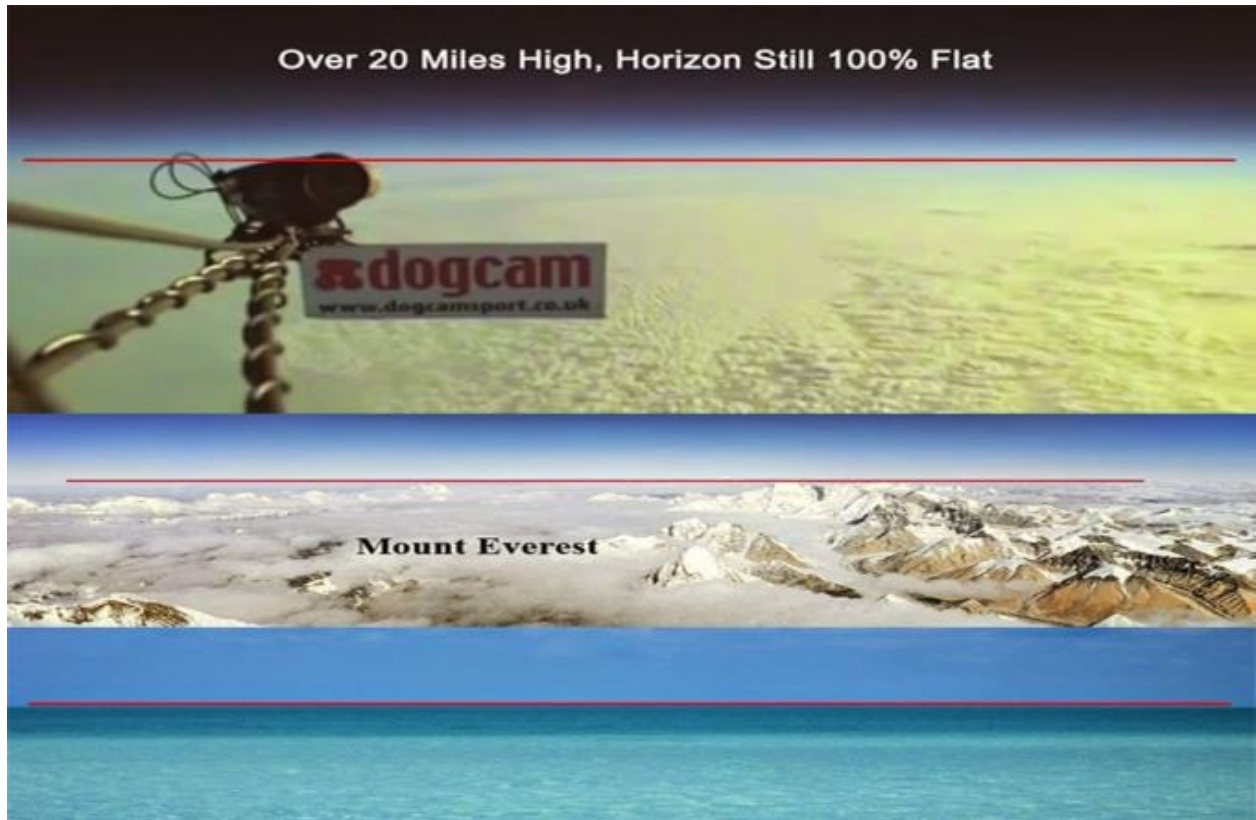

3) The natural physics of water is to find and maintain its level. If Earth were a giant sphere tilted, wobbling and hurdling through infinite space then truly flat, consistently level surfaces would not exist here. But since Earth is in fact an extended flat plane, this fundamental physical property of fluids finding and remaining level is consistent with experience and common sense.



4) Rivers run down to sea-level finding the easiest course, North, South, East, West and all other intermediary directions over the Earth at the same time. If Earth were truly a spinning ball then many of these rivers would be impossibly flowing uphill, for example the Mississippi in its 3,000 miles would have to ascend 11 miles before reaching the Gulf of Mexico.

5) One portion of the Nile River flows for a thousand miles with a fall of only one foot. Parts of the West African Congo, according to the supposed inclination and movement of the ball-Earth, would be sometimes running uphill and sometimes down. This would also be the case for the Parana, Paraguay and other long rivers.

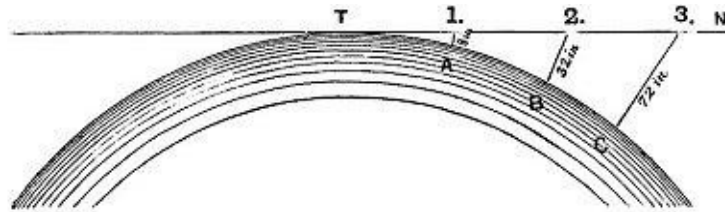

6) If Earth were a ball 25,000 miles in circumference as NASA and modern astronomy claim, spherical trigonometry dictates the surface of all standing water must curve downward an easily measurable 8 inches per mile multiplied by the square of the distance. This means along a 6 mile channel of standing water, the Earth would dip 6 feet on either end from the central peak. Every time such experiments have been conducted, however, standing water has proven to be perfectly level.



7) Surveyors, engineers and architects are never required to factor the supposed curvature of the Earth into their projects. Canals, railways, bridges and tunnels for example are always cut and laid horizontally, often over hundreds of miles

without any allowance for curvature.

8) The Suez Canal connecting the Mediterranean with the Red Sea is 100 miles long without any locks making the water an uninterrupted continuation of the two seas. When constructed, the Earth's supposed curvature was not taken into account, it was dug along a horizontal datum line 26 feet below sea-level, passing through several lakes from one sea to the other, with the datum line and water's surface running perfectly parallel over the 100 miles.



9) Engineer W. Winckler was published in the [Earth Review](#) (page 24) regarding the Earth's supposed curvature, stating, *“As an engineer of many years standing, I saw that this absurd allowance is only permitted in school books. No engineer would dream of allowing anything of the kind. I have projected many miles of railways and many more of canals and the allowance has not even been thought of, much less allowed for. This allowance for curvature means this - that it is 8” for the first mile of a canal, and increasing at the ratio by the square of the distance in miles; thus a small navigable canal for boats, say 30 miles long, will have, by the above rule an allowance for curvature of 600 feet. Think of that and*

then please credit engineers as not being quite such fools. Nothing of the sort is allowed. We no more think of allowing 600 feet for a line of 30 miles of railway or canal, than of wasting our time trying to square the circle.”



10) The London and Northwestern Railway forms a straight line 180 miles long between London and Liverpool. The railroad’s highest point, midway at Birmingham station, is only 240 feet above sea-level. If the world were actually a globe, however, curving 8 inches per mile squared, the 180 mile stretch of rail would form an arc with the center point at Birmingham raising over a mile, a full 5,400 feet above London and Liverpool.



11) A surveyor and engineer of thirty years published in the Birmingham Weekly Mercury stated, *“I am thoroughly acquainted with the theory and practice of civil engineering. However bigoted some of our professors may be in the theory of surveying according to the prescribed rules, yet it is well known amongst us that such theoretical measurements are INCAPABLE OF ANY PRACTICAL ILLUSTRATION. All our locomotives are designed to run on what may be regarded as TRUE LEVELS or FLATS. There are, of course, partial inclines or gradients here and there, but they are always accurately defined and must be carefully traversed. But anything approaching to eight inches in the mile, increasing as the square of the distance, COULD NOT BE WORKED BY ANY ENGINE THAT WAS EVER YET CONSTRUCTED. Taking one station with another all over England and Scotland, it may be stated that all the platforms are ON THE SAME RELATIVE LEVEL. The distance between Eastern and Western coasts of England may be set down as 300 miles. If the prescribed curvature was indeed as represented, the central stations at Rugby or Warwick ought to be close upon three miles higher than a chord drawn from the two extremities. If such was the case there is not a driver or stoker within the*

*Kingdom that would be found to take charge of the train. We can only laugh at those of your readers who seriously give us credit for such venturesome exploits, as running trains round spherical curves. Horizontal curves on levels are dangerous enough, vertical curves would be a thousand times worse, and with our rolling stock constructed as at present **physically impossible.**”*



12) The Manchester Ship Canal Company published in the [Earth Review](#) (page 24) stated, “*It is customary in Railway and Canal constructions for all levels to be referred to a datum which is nominally horizontal and is so shown on all sections. It is not the practice in laying out Public Works to make allowances for the curvature of the earth.*” This statement is also published in the book "[Zetetic Cosmogony](#)" on page 23.

13) In a 19th century French experiment by M. M. Biot and Arago a powerful lamp with good reflectors was placed on the summit of Desierto las Palmas in Spain and able to be seen all the way from Camprey on the Island of Iviza. Since the elevation of the two points were identical and the distance between covered nearly 100 miles, if Earth were a ball 25,000 miles in circumference, the light should have been more than 6,600 feet, a mile and a quarter, below the line of sight!

14) The Lieutenant-Colonel Portlock experiment used oxy-hydrogen Drummond's lights and heliostats to reflect the sun's rays across stations set up across 108 miles of St. George's Channel. If the Earth were actually a ball 25,000 miles in circumference, Portlock's light should have remained hidden under a mile and a half of curvature.

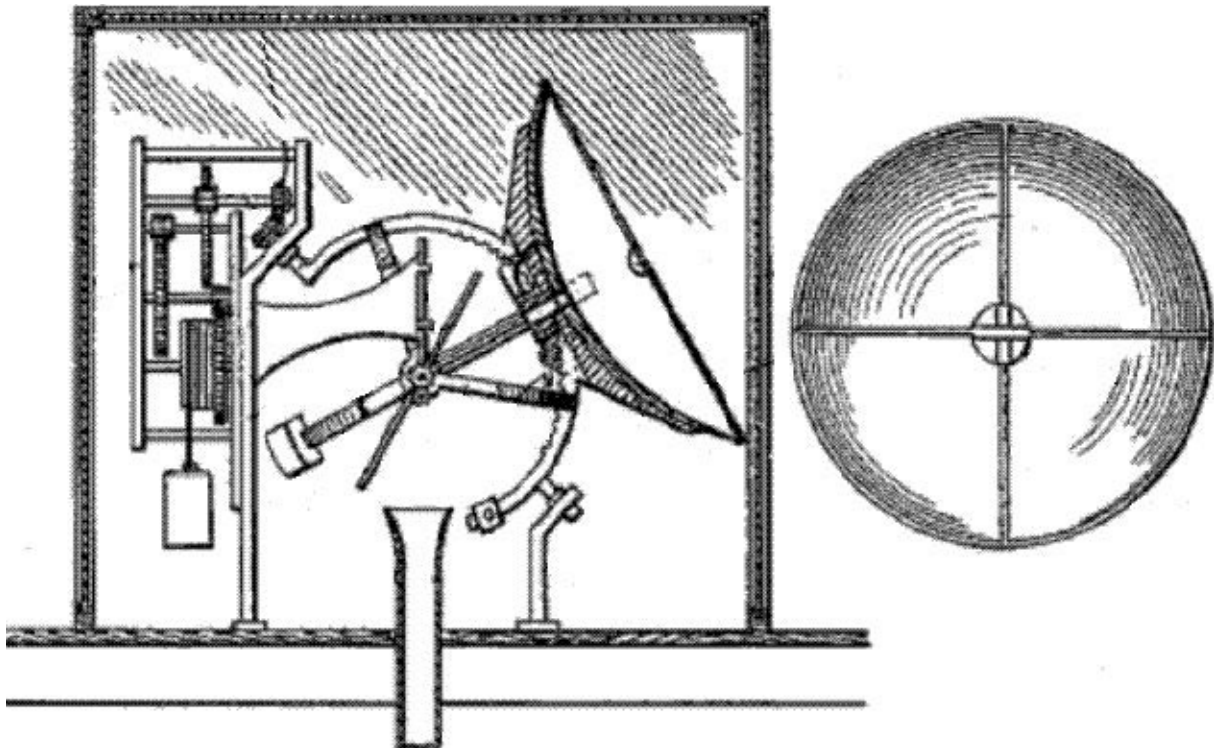

15) If the Earth were truly a sphere 25,000 miles in circumference, airplane pilots would have to constantly correct their altitudes downwards so as to not fly straight off into "outer space;" a pilot wishing to simply maintain their altitude at

a typical cruising speed of 500 mph, would have to constantly dip their nose downwards and descend 2,777 feet (over half a mile) every minute! Otherwise, without compensation, in one hour's time the pilot would find themselves 31.5 miles higher than expected.



16) The experiment known as “Airy’s Failure” proved that the stars move relative to a stationary Earth and not the other way around. By first filling a telescope with water to slow down the speed of light inside, then calculating the tilt necessary to get the starlight directly down the tube, Airy failed to prove the heliocentric theory since the starlight was already coming in the correct angle with no change necessary, and instead proved the geocentric model correct.

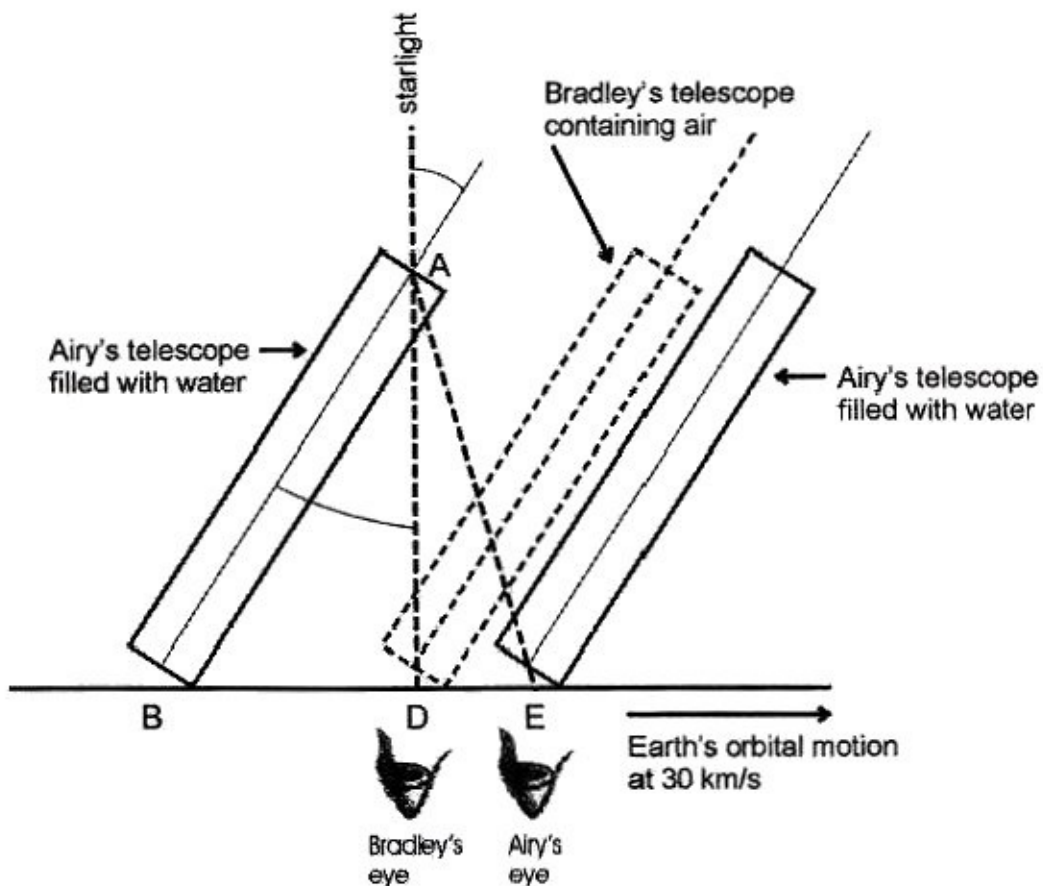

[View: An animated explanation of "Airy's Failure"](#)

17) “Olber’s Paradox” states that if there were billions of stars which are suns the night sky would be filled completely with light. As Edgar Allen Poe said ([The Works of Edgar Allen Poe, volume IX](#), page 95), “*Were the succession of stars endless, then the background of the sky would present us an uniform luminosity, since there could be absolutely no point, in all that background, at which would not exist a star.*” In fact Olber’s “Paradox” is no more a paradox than George Airy’s experiment was a “failure.” Both are actually excellent refutations of the heliocentric spinning ball model.

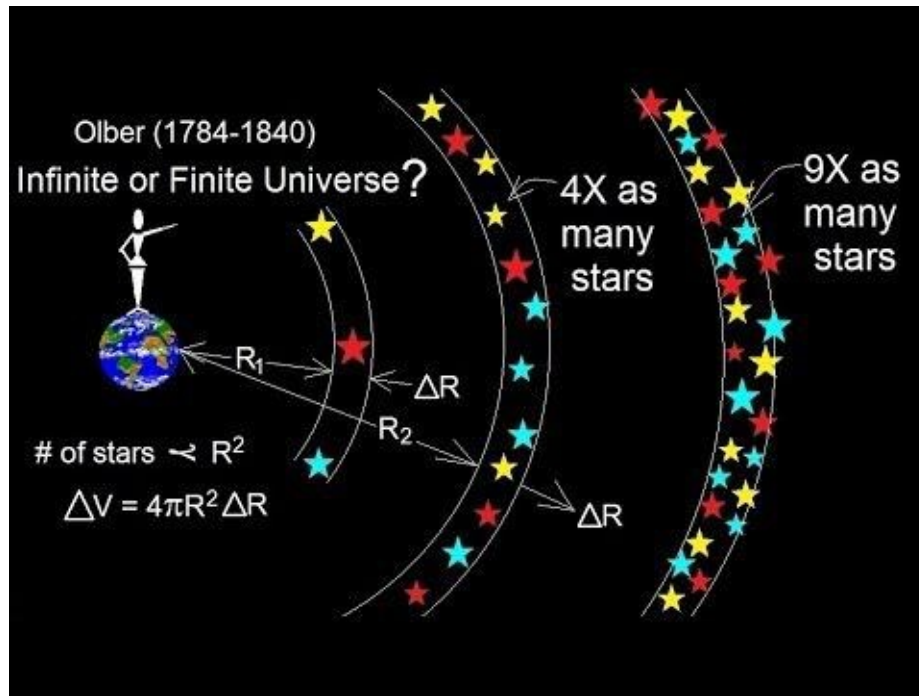

18) The Michelson-Morley and Sagnac experiments attempted to measure the change in speed of light due to Earth's assumed motion through space. After measuring in every possible different direction in various locations they failed to detect any significant change whatsoever, again proving the stationary geocentric model.

Sagnac's Experiment

In 1913, Sagnac carried out a simple experiment of passing light in opposite directions around a table and recombining them. This produced interference fringes. He then rotated the whole table at 2 revolutions per second and found that the fringes changed. This result has very significant implications in science.

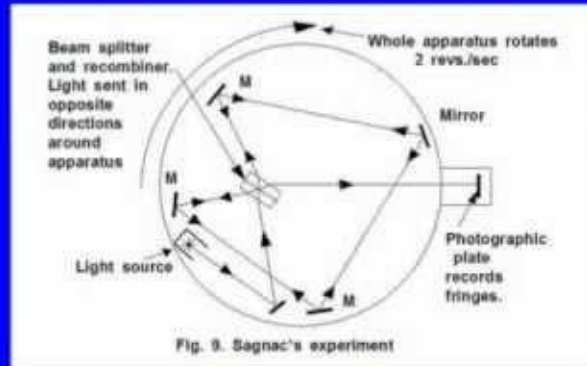

[View: Sagnac's Experiment - An animated explanation](#)

19) Tycho Brahe famously argued against the heliocentric theory in his time, positing that if the Earth revolved around the Sun, the change in relative position of the stars after 6 months orbital motion could not fail to be seen. He argued that the stars should seem to separate as we approach and come together as we recede. In actual fact, however, after 190,000,000 miles of supposed orbit around the Sun, not a single inch of parallax can be detected in the stars, proving we have not moved at all.

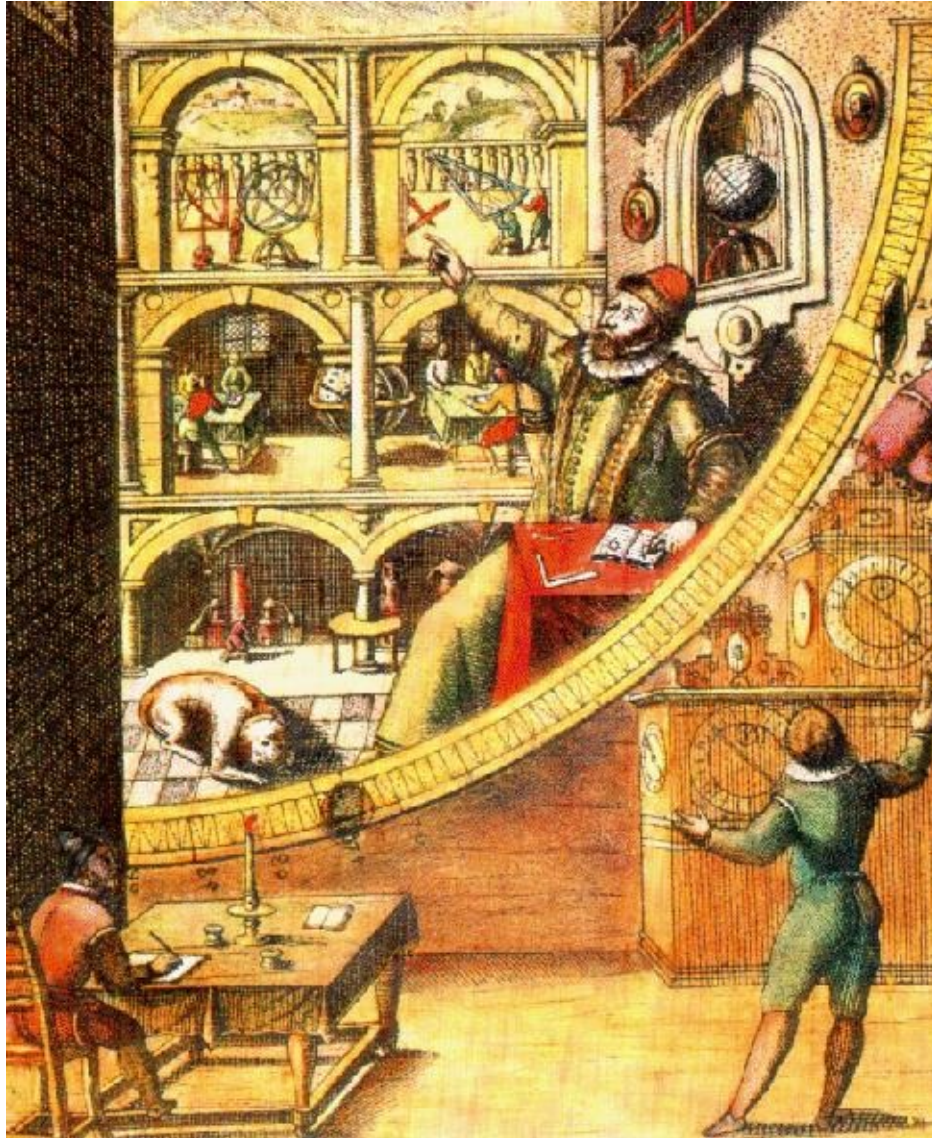

20) If Earth were truly constantly spinning Eastwards at over 1,000 mph, vertically-fired cannonballs and other projectiles should fall significantly due west. In actual fact, however, whenever this has been tested, vertically-fired cannonballs shoot upwards an average of 14 seconds ascending, 14 seconds descending, and fall back to the ground no more than 2 feet away from the cannon, often directly back into the muzzle.

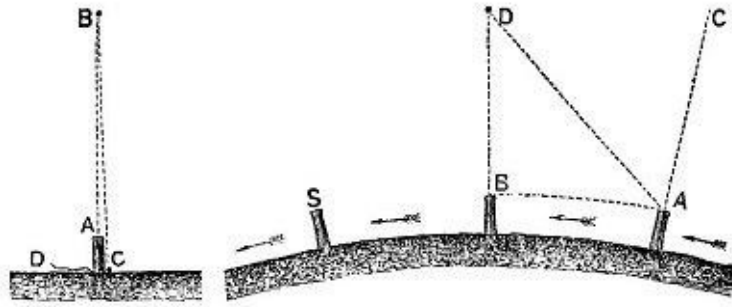

21) If the Earth were truly constantly spinning Eastwards at over 1,000 mph, helicopters and hot-air balloons should be able to simply hover over the surface of the Earth and wait for their destinations to come to them!



22) If Earth were truly constantly spinning Eastwards at over 1,000 mph, during the Red Bull stratosphere dive, Felix Baumgartner, spending 3 hours ascending over New Mexico, should have landed 2,500 miles West into the Pacific Ocean but instead landed a few dozen miles East of the take-off point.

23) Ball-believers often claim “gravity” magically and inexplicably drags the entire lower-atmosphere of the Earth in perfect synchronization up to some undetermined height where this progressively faster spinning atmosphere gives way to the non-spinning, non-gravitized, non-atmosphere of infinite vacuum space. Such non-sensical theories are debunked, however, by rain, fireworks, birds, bugs, clouds, smoke, planes and projectiles all of which would behave very differently if both the ball-Earth and its atmosphere were constantly spinning Eastwards at 1,000 mph.



24) If Earth and its atmosphere were constantly spinning eastwards over 1,000 mph then North/South facing cannons should establish a control while East-firing cannonballs should fall significantly farther than all others while West-firing cannonballs should fall significantly closer. In actual fact, however, regardless of which direction cannons are fired, the distance covered is always the same.

25) If Earth and its atmosphere were constantly spinning eastwards over 1,000 mph, then the average commercial airliner traveling 500 mph should never be able to reach its Eastward destinations before they come speeding up from

behind! Likewise Westward destinations should be arrived at thrice the speed, but this is not the case.

26) Quoting “[Heaven and Earth](#)” (page 10) by Gabrielle Henriet, *“If flying had been invented at the time of Copernicus, there is no doubt that he would have soon realized that his contention regarding the rotation of the earth was wrong, on account of the relation existing between the speed of an aircraft and that of the earth’s rotation. If the earth rotates, as it is said, at 1,000 miles an hour, and a plane flies in the same direction at only 500 miles, it is obvious that its place of destination will be farther removed every minute. On the other hand, if flying took place in the direction opposite to that of the rotation, a distance of 1,500 miles would be covered in one hour, instead of 500, since the speed of the rotation is to be added to that of the plane. It could also be pointed out that such a flying speed of 1,000 miles an hour, which is supposed to be that of the earth’s rotation, has recently been achieved, so that an aircraft flying at this rate in the same direction as that of the rotation could not cover any ground at all. It would remain suspended in mid-air over the spot from which it took off, since both speeds are equal.”*

27) If Earth and its atmosphere were constantly spinning Eastwards over 1,000 mph, landing airplanes on such fast-moving runways which face all manner of directions North, South, East, West and otherwise would be practically impossible, yet in reality such fictional concerns are completely negligible.

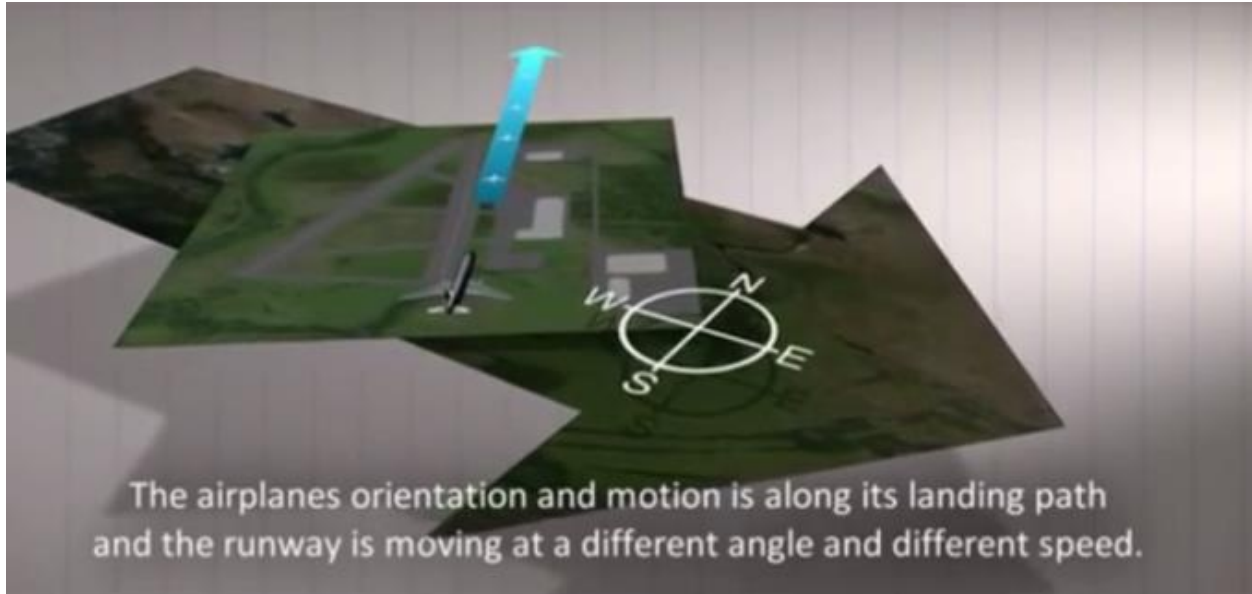

28) If the Earth and its atmosphere were constantly spinning Eastwards over 1,000 mph, then clouds, wind and weather patterns could not casually and unpredictably go every which way, with clouds often travelling in opposing directions at varying altitudes simultaneously.

29) If the Earth and its atmosphere were constantly spinning Eastwards over 1,000 mph, this should somewhere somehow be seen, heard, felt or measured by someone, yet no one in history has ever experienced this alleged Eastward motion; meanwhile, however, we can hear, feel and experimentally measure even the slightest Westward breeze.



30) In his book “South Sea Voyages,” Arctic and Antarctic explorer Sir James Clarke Ross, described his experience on the night of November 27th, 1839 and his conclusion that the Earth must be motionless: *“The sky being very clear ... it enabled us to observe the higher stratum of clouds to be moving in an exactly opposite direction to that of the wind--a circumstance which is frequently recorded in our meteorological journal both in the north-east and south-east trades, and has also often been observed by former voyagers. Captain Basil Hall witnessed it from the summit of the Peak of Teneriffe; and Count Strzelechi, on ascending the volcanic mountain of Kiranea, in Owhyhee, reached at 4,000 feet an elevation above that of the trade wind, and experienced the influence of an opposite current of air of a different hygrometric and thermometric condition ... Count Strzelechi further informed me of the following seemingly anomalous circumstance--that at the height of 6,000 feet he found the current of air blowing at right angles to both the lower strata, also of a different hygrometric and thermometric condition, but warmer than the inter-stratum. **Such a state of the atmosphere is compatible only with the fact which other evidence has***

demonstrated, that the earth is at rest.”



31) Quoting “[Zetetic Cosmogony](#)” (pages 68/69) Thomas Winships states: “*Let ‘imagination’ picture to the mind what force air would have which was set in motion by a spherical body of 8,000 miles in diameter, which in one hour was spinning round 1,000 mph, rushing through space at 65,000 mph and gyrating across the heavens? Then let ‘conjecture’ endeavor to discover whether the inhabitants on such a globe could keep their hair on? If the earth-globe rotates on its axis at the terrific rate of 1,000 miles an hour, such an immense mass would of necessity cause a tremendous rush of wind in the space it occupied. The wind would go all one way, and anything like clouds which got ‘within the sphere of influence’ of the rotating sphere, would have to go the same way. **The fact that the earth is at rest is proved by kite flying.***”

32) If “gravity” is credited with being a force strong enough to hold the world’s oceans, buildings, people and atmosphere stuck to the surface of a rapidly spinning ball, then it is impossible for “gravity” to also simultaneously be weak enough to allow little birds, bugs, and planes to take-off and travel freely

unabated in any direction.

33) If “gravity” is credited with being a force strong enough to curve the massive expanse of oceans around a globular Earth, it would be impossible for fish and other creatures to swim through such forcefully held water.

34) Ship captains in navigating great distances at sea never need to factor the supposed curvature of the Earth into their calculations. Both Plane Sailing and Great Circle Sailing, the most popular navigation methods, use plane, not spherical trigonometry, making all mathematical calculations on the assumption that the Earth is perfectly flat. If the Earth were in fact a sphere, such an errant assumption would lead to constant glaring inaccuracies. Plane Sailing has worked perfectly fine in both theory and practice for thousands of years, however, and plane trigonometry has time and again proven **more** accurate than spherical trigonometry in determining distances across the oceans.

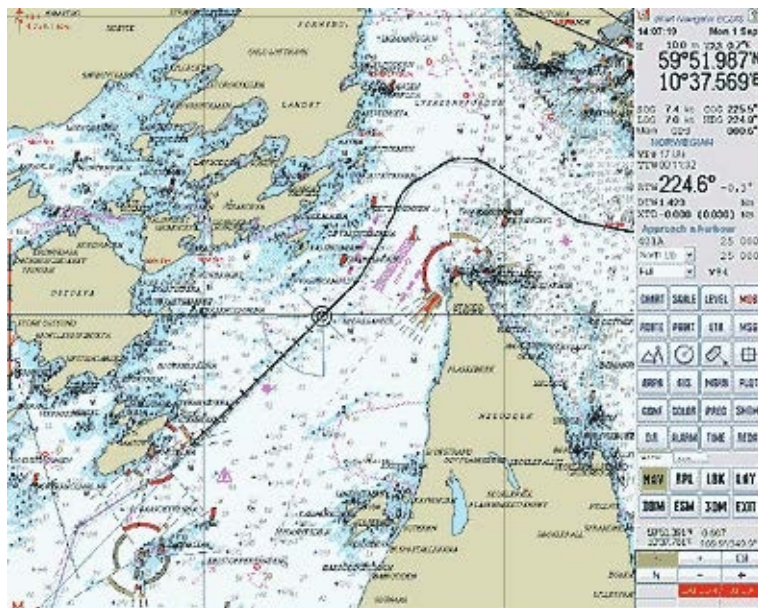

35) If the Earth were truly a globe, then every line of latitude south of the equator would have to measure a gradually smaller and smaller circumference the farther South travelled. If, however, the Earth is an extended plane, then

every line of latitude south of the equator should measure a gradually larger and larger circumference the farther South travelled. The fact that many captains navigating south of the equator assuming the globular theory have found themselves drastically out of reckoning, more so the farther South travelled, testifies to the fact that the Earth is not a ball.



36) During Captain James Clarke Ross's voyages around the Antarctic circumference, he often wrote in his journal perplexed at how they routinely found themselves out of accordance with their charts, stating that they found themselves an average of 12-16 miles outside their reckoning every day, later on further south as much as 29 miles.



37) Lieutenant Charles Wilkes commanded a United States Navy exploration expedition to the Antarctic from 1838 to 1842, and in his journals also mentioned being consistently east of his reckoning, sometimes over 20 miles in less than 18 hours.

38) To quote Reverend Thomas Milner's "[The Gallery of Nature](#)" (page 365), *"In the southern hemisphere, navigators to India have often fancied themselves east of the Cape when still west, and have been driven ashore on the African coast, which, according to their reckoning, lay behind them. This misfortune happened to a fine frigate, the Challenger, in 1835. How came Her Majesty's Ship 'Conqueror,' to be lost? How have so many other noble vessels, perfectly sound, perfectly manned, perfectly navigated, been wrecked in calm weather, not only in dark night, or in a fog, but in broad daylight and sunshine - in the former case upon the coasts, in the latter, upon sunken rocks - from being 'out of reckoning?'"* The simple answer is that Earth is not a ball.

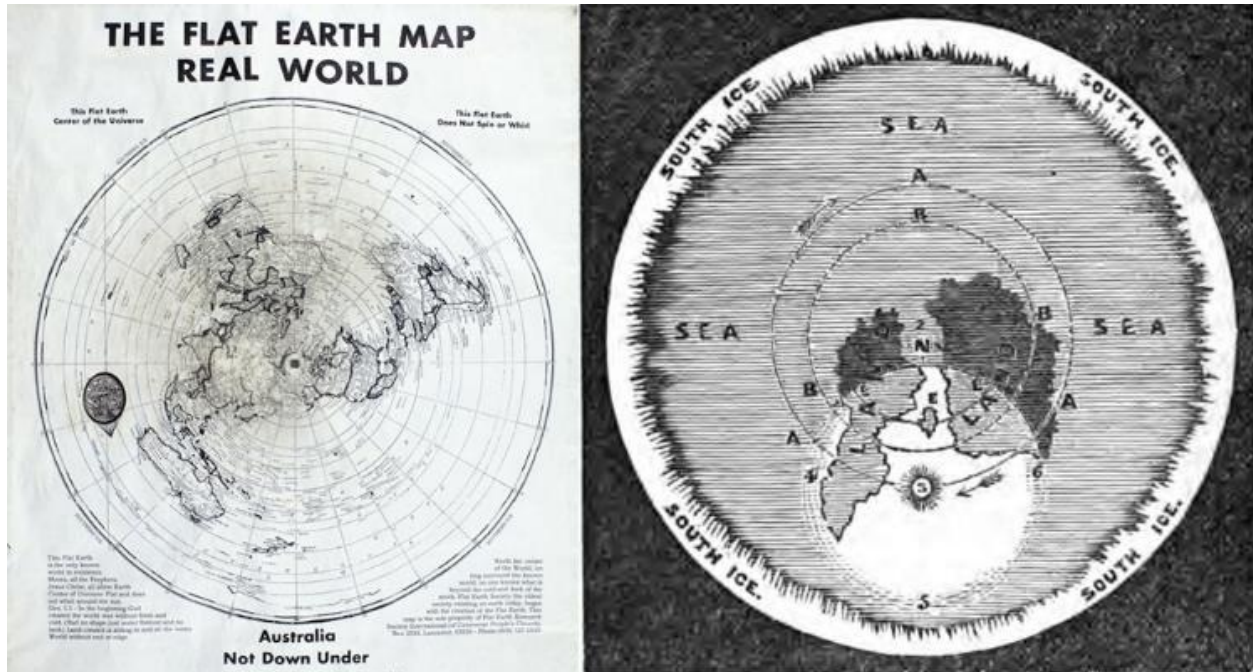

39) Practical distance measurements taken from “The Australian Handbook, Almanac, Shippers’ and Importers’ Directory” state that the straight line distance between Sydney and Nelson is 1,550 statute miles. Their given difference in longitude is 22 degrees 2’14”. Therefore if 22 degrees 2’14” out of 360 is 1,550 miles, the entirety would measure 25,182 miles. This is not only larger than the ball-Earth is said to be at the equator, but a whole 4,262 miles greater than it would be at Sydney’s southern latitude on a globe of said proportions.

40) From near Cape Horn, Chile to Port Philip in Melbourne, Australia the distance is 10,500 miles, or 143 degrees of longitude away. Factoring in the remaining degrees to 360 makes for a total distance of 26,430 miles around this particular latitude, which is over 1,500 miles wider than Earth is supposed to be at the equator, and many more thousands of miles wider than it is supposed to be at such Southern latitudes.

41) Similar calculations made from the Cape of Good Hope, South Africa to Melbourne, Australia at an average latitude of 35.5 degrees South, have given an approximate figure of over 25,000 miles, which is again equal to or greater than

the Earth's supposed greatest circumference at the equator. Calculations from Sydney, Australia to Wellington, New Zealand at an average of 37.5 degrees South have given an approximate circumference of 25,500 miles, greater still! According to the ball-Earth theory, the circumference of the Earth at 37.5 degrees Southern latitude should be only 19,757 statute miles, almost six thousand miles less than such practical measurements.



42) In the ball-Earth model Antarctica is an ice continent which covers the bottom of the ball from 78 degrees South latitude to 90 and is therefore not more than 12,000 miles in circumference. Many early explorers including Captian Cook and James Clark Ross, however, in attempting Antarctic circumnavigation took 3 to 4 years and clocked 50-60,000 miles around. The British ship Challenger also made an indirect but complete circumnavigation of Antarctica traversing 69,000 miles. This is entirely inconsistent with the ball model.



43) If Earth was a ball there are several flights in the Southern hemisphere which would have their quickest, straightest path over the Antarctic continent such as Santiago, Chile to Sydney, Australia. Instead of taking the shortest, quickest route in a straight line over Antarctica, all such flights detour all manner of directions away from Antarctica instead claiming the temperatures too cold for airplane travel! Considering the fact that there are plenty of flights to/from/over Antarctica, and NASA claims to have technology keeping them in conditions far colder (and far hotter) than any experienced on Earth, such an excuse is clearly just an excuse, and these flights aren't made because they are impossible.

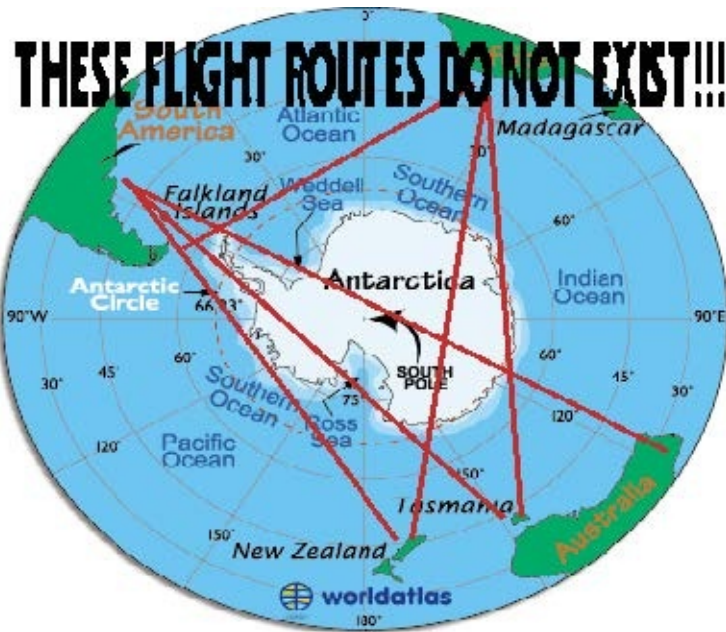

44) If Earth was a ball, and Antarctica was too cold to fly over, the only logical way to fly from Sydney to Santiago would be a straight shot over the Pacific staying in the Southern hemisphere the entire way. Re-fueling could be done in New Zealand or other Southern hemisphere destinations along the way if absolutely necessary. In actual fact, however, Santiago-Sydney flights go into the Northern hemisphere making stop-overs at LAX and other North American airports before continuing back down to the Southern hemisphere. Such ridiculously wayward detours make no sense on the globe but make perfect sense and form nearly straight lines when shown on a flat Earth map.

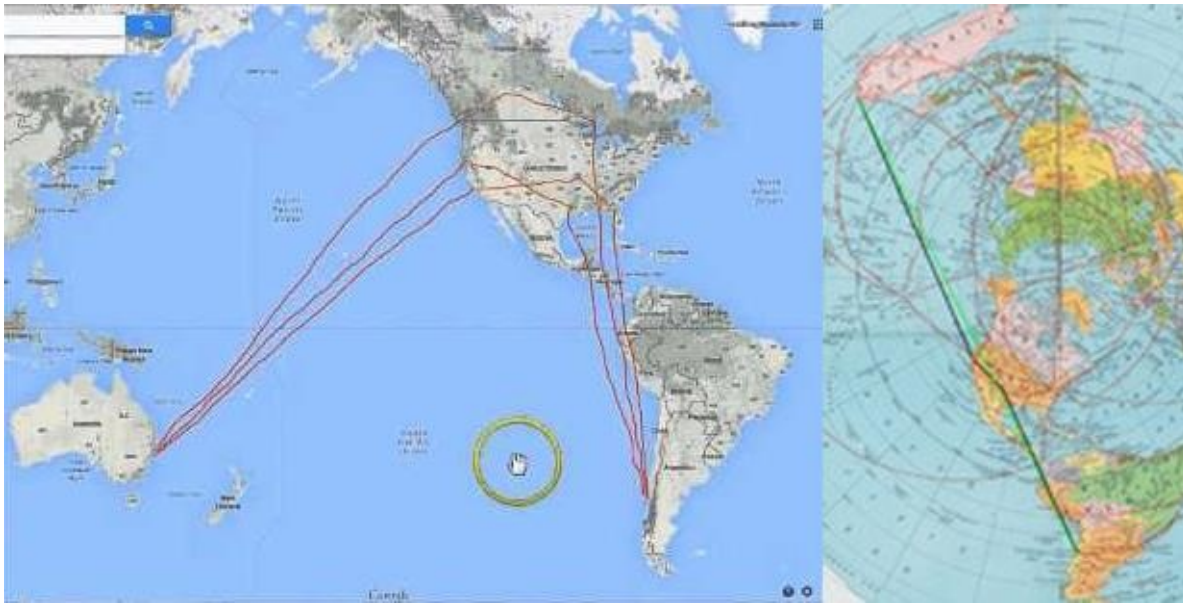

45) On a ball-Earth, Johannesburg, South Africa to Perth, Australia should be a straight shot over the Indian Ocean with convenient re-fueling possibilities on Mauritius or Madagascar. In actual practice, however, most Johannesburg to Perth flights curiously stop over either in Dubai, Hong Kong or Malaysia all of which make no sense on the ball, but are completely understandable when mapped on a flat Earth.



46) On a ball-Earth Cape Town, South Africa to Buenos Aries, Argentina should be a straight shot over the Atlantic following the same line of latitude across, but instead every flight goes to connecting locations in the Northern hemisphere first, stopping over anywhere from London to Turkey to Dubai. Once again these make absolutely no sense on the globe but are completely understandable options when mapped on a flat Earth.



47) On a ball-Earth Johannesburg, South Africa to São Paulo, Brazil should be a quick straight shot along the 25th Southern latitude, but instead nearly every flight makes a re-fueling stop at the 50th degree North latitude in London first! The only reason such a ridiculous stop-over works in reality is because the Earth is flat.



48) On a ball-Earth Santiago, Chile to Johannesburg, South Africa should be an easy flight all taking place below the Tropic of Capricorn in the Southern hemisphere, yet every listed flight makes a curious re-fueling stop in Senegal near the Tropic of Cancer in the North hemisphere first! When mapped on a flat

Earth the reason why is clear to see, however, Senegal is actually directly in a straight-line path half-way between the two.



49) If Earth were a spinning ball heated by a Sun 93 million miles away, it would be impossible to have simultaneously sweltering summers in Africa while just a few thousand miles away bone-chilling frozen Arctic/Antarctic winters experiencing little to no heat from the Sun whatsoever. If the heat from the Sun traveled 93,000,000 miles to the Sahara desert, it is absurd to assert that another 4,000 miles (0.00004%) further to Antarctica would completely negate such sweltering heat resulting in such drastic differences.

50) If the Earth were truly a globe, the Arctic and Antarctic polar regions and areas of comparable latitude North and South of the equator should share similar conditions and characteristics such as comparable temperatures, seasonal changes, length of daylight, plant and animal life. In reality, however, the Arctic/Antarctic regions and areas of comparable latitude North/South of the equator differ greatly in many ways entirely inconsistent with the ball model and entirely consistent with the flat model.



51) Antarctica is by far the coldest place on Earth with an average annual temperature of approximately -57 degrees Fahrenheit, and a record low of -135.8! The average annual temperature at the North Pole, however, is a comparatively warm 4 degrees. Throughout the year, temperatures in the Antarctic vary less than half the amount at comparable Arctic latitudes. The Northern Arctic region enjoys moderately warm summers and manageable winters, whereas the Southern Antarctic region never even warms enough to melt the perpetual snow and ice. On a tilting, wobbling, ball-Earth spinning uniformly around the Sun, Arctic and Antarctic temperatures and seasons should not vary so greatly.

52) Iceland at 65 degrees North latitude is home to 870 species of native plants and abundant various animal life. Compare this with the Isle of Georgia at just 54 degrees South latitude where there are only 18 species of native plants and animal life is almost non-existent. The same latitude as Canada or England in the North where dense forests of various tall trees abound, the infamous Captain Cook wrote of Georgia that he was unable to find a single shrub large enough to make a toothpick! Cook wrote, *“Not a tree was to be seen. The lands which lie to the south are doomed by nature to perpetual frigidness - never to feel the warmth of the sun’s rays; whose horrible and savage aspect I have not words to*

describe. Even marine life is sparse in certain tracts of vast extent, and the sea-bird is seldom observed flying over such lonely wastes. The contrasts between the limits of organic life in Arctic and Antarctic zones is very remarkable and significant.”

Arctic Winter, Arctic Summer



53) At places of comparable latitude North and South, the Sun behaves very differently than it would on a spinning ball Earth but precisely how it should on a flat Earth. For example, the longest summer days North of the equator are much longer than those South of the equator, and the shortest winter days North of the equator are much shorter than the shortest South of the equator. This is inexplicable on a uniformly spinning, wobbling ball Earth but fits exactly on the flat model with the Sun traveling circles over and around the Earth from Tropic to Tropic.

54) At places of comparable latitude North and South, dawn and dusk happen very differently than they would on a spinning ball, but precisely how they should on a flat Earth. In the North dawn and dusk come slowly and last far longer than in the South where they come and go very quickly. Certain places in the North twilight can last for over an hour while at comparable Southern latitudes within a few minutes the sunlight completely disappears. This is inexplicable on a uniformly spinning, wobbling ball Earth but is exactly what is expected on a flat Earth with the Sun traveling faster, wider circles over the

South and slower, narrower circles over the North.

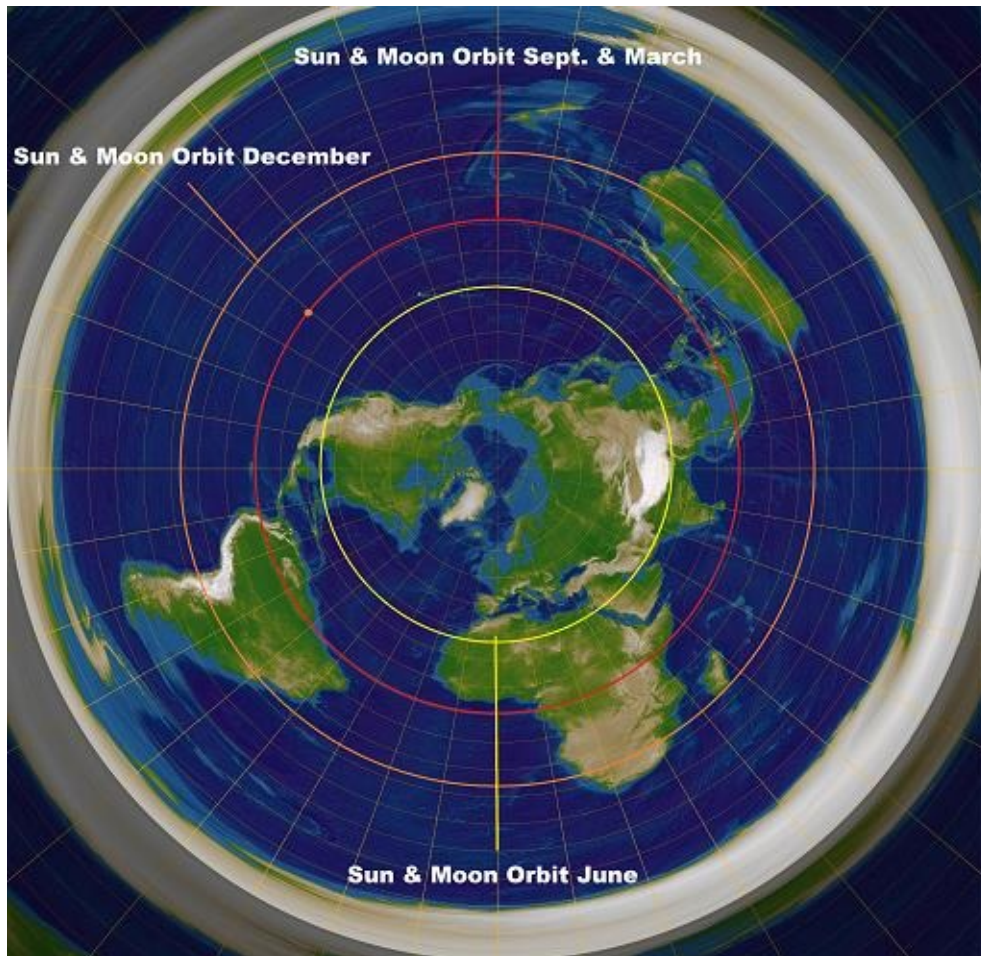

55) If the Sun circles over and around the Earth every 24 hours, steadily travelling from Tropic to Tropic every 6 months, it follows that the Northern, central region would annually receive far more heat and sunlight than the Southern circumferential region. Since the Sun must sweep over the larger Southern region in the same 24 hours it has to pass over the smaller Northern region, its passage must necessarily be proportionally faster as well. This perfectly explains the differences in Arctic/Antarctic temperatures, seasons, length of daylight, plant and animal life; this is why the Antarctic morning dawn and evening twilight are very abrupt compared with the North; and this explains why many midsummer Arctic nights the Sun does not set at all!

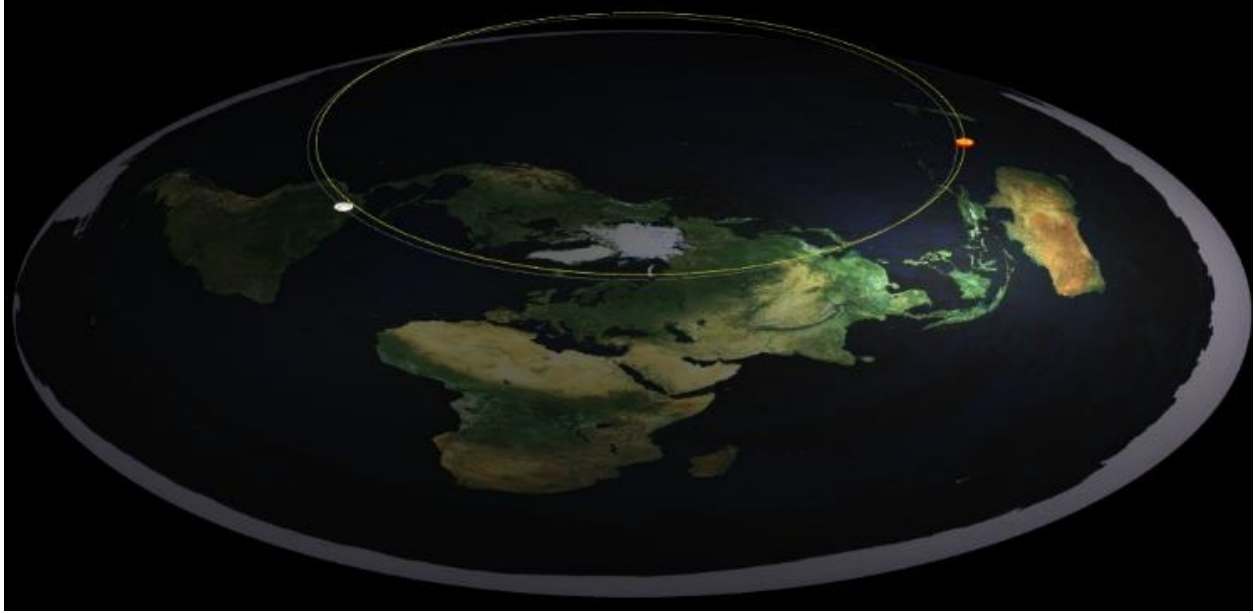

56) The “Midnight Sun” is an Arctic phenomenon occurring annually during the summer solstice where for several days straight an observer significantly far enough north can watch the Sun traveling circles overhead, rising and falling in the sky throughout the day, but never fully setting for upwards of 72+ hours! If the Earth were actually a spinning globe revolving around the Sun, the only place such a phenomenon as the Midnight Sun could be observed would be at the poles. Any other vantage point from 89 degrees latitude downwards could never, regardless of any tilt or inclination, see the Sun for 24 hours straight. To see the Sun for an entire revolution on a spinning globe at a point other than the poles, you would have to be looking through miles and miles of land and sea for part of the revolution!



57) The establishment claims the Midnight Sun IS experienced in Antarctica but they conveniently do not have any uncut videos showing this, nor do they allow independent explorers to travel to Antarctica during the winter solstice to verify or refute these claims. Conversely, there are dozens of uncut videos publicly available showing the Arctic Midnight Sun and it has been verified beyond any shadow of a doubt.

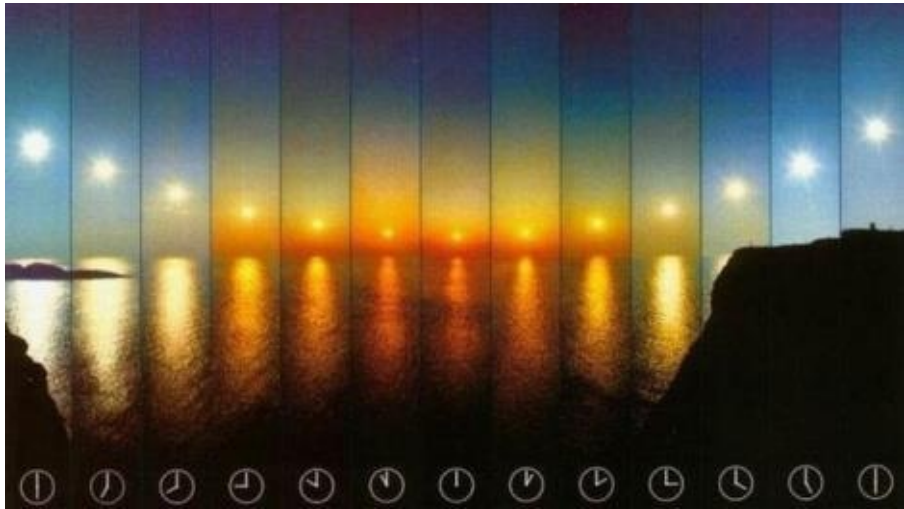

58) The Royal Belgian Geographical Society in their “Expedition Antarctique Belge,” recorded that during the most severe part of the Antarctic winter, from 71 degrees South latitude onwards, the sun sets on May 17th and is not seen above the horizon again until July 21st! This is completely at odds with the ball-Earth theory, but easily explained by the flatEarth model. The Midnight Sun is

seen from high altitudes in extreme Northern latitudes during Arctic summer because the Sun, at its inner-most cycle, is circling tightly enough around the polar center that it remains visible above the horizon for someone at such a vantage point. Likewise, in extreme Southern latitudes during Arctic summer, the Sun completely disappears from view for over 2 months because there at the Northern Tropic, at the inner-most arc of its boomerang journey, the Sun is circling the Northern center too tightly to be seen from the Southern circumference.



59) Quoting Gabrielle Henriet ("[Heaven and Earth](#)", page 10), "*The theory of the rotation of the earth may once and for all be definitely disposed of as impracticable by pointing out the following inadvertence. It is said that the rotation takes twenty-four hours and that its speed is uniform, in which case, necessarily, days and nights should have an identical duration of twelve hours each all the year round. The sun should invariably rise in the morning and set in the evening at the same hours, with the result that it would be the equinox every day from the 1st of January to the 31st of December. One should stop and reflect on this before saying that the earth has a movement of rotation. How does the system of gravitation account for the seasonal variations in the lengths of days and nights if the earth rotates at a uniform speed in twenty-four hours!?*"

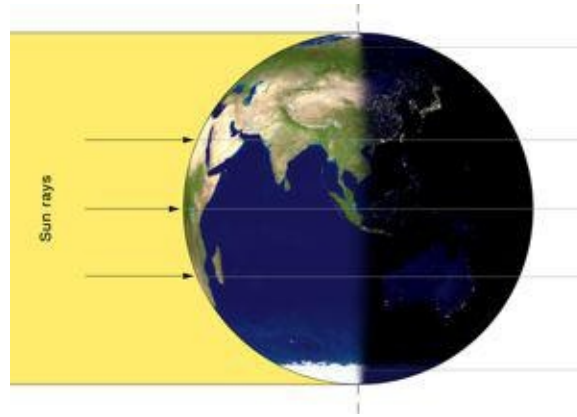

60) Anyone can prove the sea-horizon perfectly straight and the entire Earth perfectly flat using nothing more than a level, tripods and a wooden plank. At any altitude above sea-level, simply fix a 6-12 foot long, smooth, leveled board edgewise upon tripods and observe the skyline from eye-level behind it. The distant horizon will always align perfectly parallel with the upper edge of the board. Furthermore, if you move in a half-circle from one end of the board to the other whilst observing the skyline over the upper edge, you will be able to trace a clear, flat 10-20 miles depending on your altitude. This would be impossible if the Earth were a globe 25,000 miles in circumference; the horizon would align over the center of the board but then gradually, noticeably decline towards the extremities. Just ten miles on each side would necessitate an easily visible curvature of 66.6 feet from each end to the center.

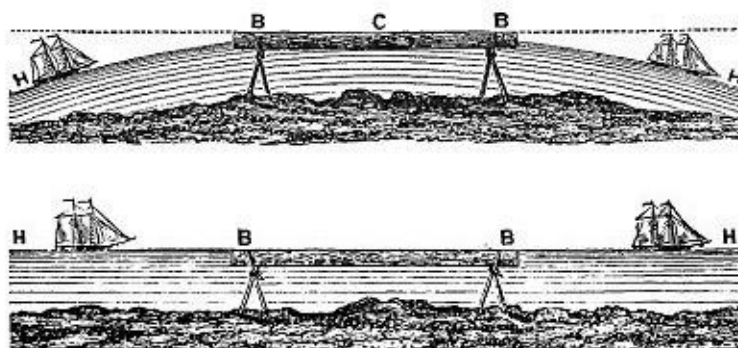

61) If the Earth were actually a big ball 25,000 miles in circumference, the horizon would be noticeably curved even at sea-level, and everything on or

approaching the horizon would appear to tilt backwards slightly from your perspective. Distant buildings along the horizon would all look like leaning towers of Pisa falling away from the observer. A hot-air balloon taking off then drifting steadily away from you, on a ball-Earth would slowly and constantly appear to lean back more and more the farther away it flew, the bottom of the basket coming gradually into view as the top of the balloon disappears from sight. In reality, however, buildings, balloons, trees, people, anything and everything at right angles to the ground/horizon remains so regardless the distance or height of the observer.



62) Samuel Rowbotham's experiments at the Old Bedford Level proved conclusively the canal's water to be completely flat over a 6 mile stretch. First he stood in the canal with his telescope held 8 inches above the surface of the water, then his friend in a boat with a 5 foot tall flag sailed the 6 miles away. If Earth were a ball 25,000 miles in circumference the 6 mile stretch of water should have comprised an arc exactly 6 feet high in the middle, so the entire boat and flag should have ultimately disappeared, when in fact the entire boat and flag remained visible at the same height for the entire journey.

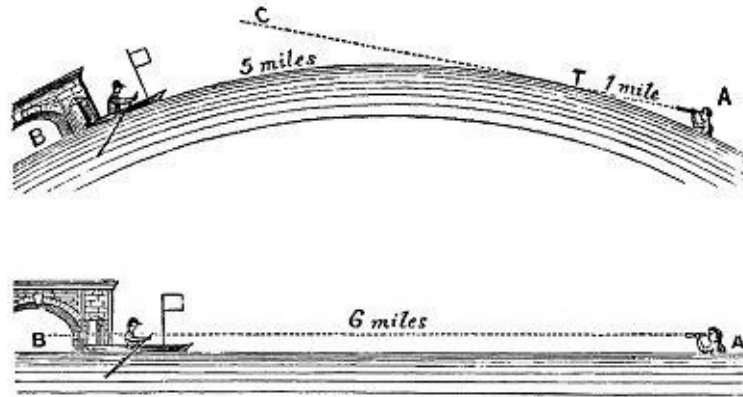

63) In a second experiment Dr. Rowbotham affixed flags 5 feet high along the shoreline, one at every mile marker. Then using his telescope mounted at 5 feet just behind the first flag looked over the tops of all 6 flags which lined up in a perfectly straight line. If the Earth were a ball 25,000 miles in circumference the flags should have progressively dipped down after the first establishing line of sight, the second would have descended 8 inches, 32 inches for the third, 6 feet for the fourth, 10 feet 8 inches for the fifth, and 16 feet 8 inches for the sixth.

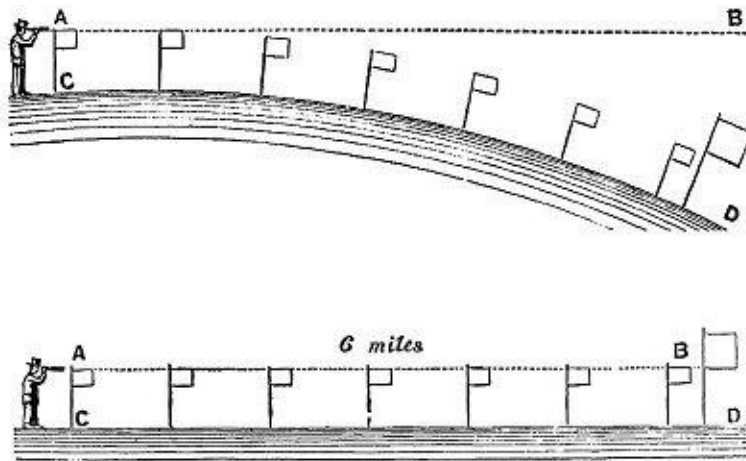

64) Quoting “[Earth Not a Globe!](#)” (1865, page 14) by Samuel Rowbotham, “*It is known that the horizon at sea, whatever distance it may extend to the right and left of the observer on land, always appears as a straight line. The following experiment has been tried in various parts of the country. At Brighton, on a rising ground near the race course, two poles were fixed in the earth six yards*

apart, and directly opposite the sea. Between these poles a line was tightly stretched parallel to the horizon. From the center of the line the view embraced not less than 20 miles on each side making a distance of 40 miles. A vessel was observed sailing directly westwards; the line cut the rigging a little above the bulwarks, which it did for several hours or until the vessel had sailed the whole distance of 40 miles. The ship coming into view from the east would have to ascend an inclined plane for 20 miles until it arrived at the center of the arc, whence it would have to descend for the same distance. The square of 20 miles multiplied by 8 inches gives 266 feet as the amount the vessel would be below the line at the beginning and at the end of the 40 miles.”

65) Also Quoting Dr. Rowbotham (“[Earth Not a Globe!](#)” 1881, page 44), “On the shore near Waterloo, a few miles to the north of Liverpool, a good telescope was fixed, at an elevation of 6 feet above the water. It was directed to a large steamer, just leaving the River Mersey, and sailing out to Dublin. Gradually the mast-head of the receding vessel came nearer to the horizon, until, at length, after more than four hours had elapsed, it disappeared. The ordinary rate of sailing of the Dublin steamers was fully eight miles an hour; so that the vessel would be, at least, thirty-two miles distant when the mast-head came to the horizon. The 6 feet of elevation of the telescope would require three miles to be deducted for convexity, which would leave twenty-nine miles, the square of which, multiplied by 8 inches, gives 560 feet; deducting 80 feet for the height of the main-mast, and we find that, according to the doctrine of rotundity, the mast-head of the outward bound steamer should have been 480 feet below the horizon. Many other experiments of this kind have been made upon sea-going steamers, and always with results entirely incompatible with the theory that the earth is a globe.”

66) Dr. Rowbotham conducted several other experiments using telescopes, spirit levels, sextants and “theodolites,” special precision instruments used for

measuring angles in horizontal or vertical planes. By positioning them at equal heights aimed at each other successively he proved over and over the Earth to be perfectly flat for miles without a single inch of curvature. His findings caused quite a stir in the scientific community and thanks to 30 years of his efforts, the shape of the Earth became a hot topic of debate around the turn of the nineteenth century.

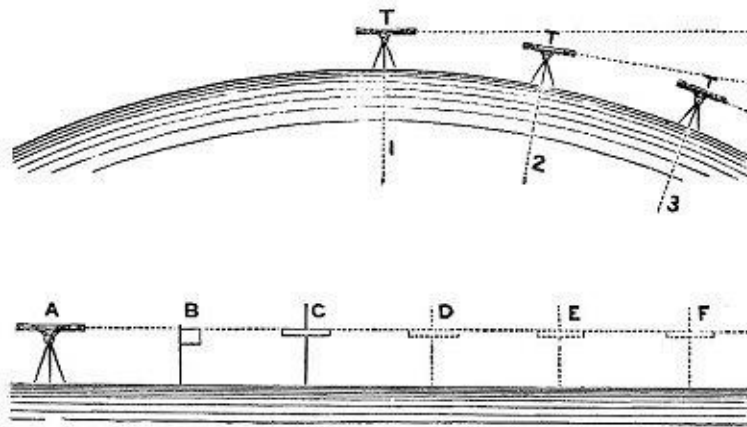

67) The distance across the Irish Sea from the Isle of Man's Douglas Harbor to Great Orm's Head in North Wales is 60 miles. If the Earth was a globe then the surface of the water between them would form a 60 mile arc, the center towering 1,944 feet higher than the coastlines at either end. It is well-known and easily verifiable, however, that on a clear day, from a modest altitude of 100 feet, the Great Orm's Head is visible from Douglas Harbor. This would be completely impossible on a globe of 25,000 miles. Assuming the 100 foot altitude causes the horizon to appear approximately 13 miles off, the 47 miles remaining means the Welsh coastline should still fall an impossible 1,472 feet below the line of sight!

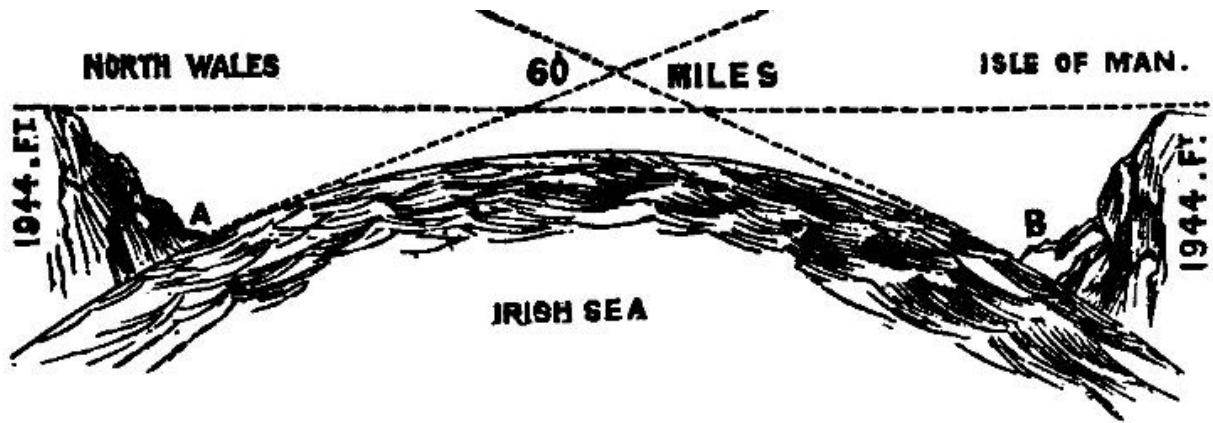

68) The Philadelphia skyline is clearly visible from Apple Pie Hill in the New Jersey Pine Barrens 40 miles away. If Earth were a ball 25,000 miles in circumference, factoring in the 205 foot elevation of Apple Pie Hill, the Philly skyline should remain well-hidden beyond 335 feet of curvature.



69) The New York City skyline is clearly visible from Harriman State Park's Bear Mountain 60 miles away. If Earth were a ball 25,000 miles in circumference, viewing from Bear Mountain's 1,283 foot summit, the

Pythagorean Theorem determining distance to the horizon being 1.23 times the square root of the height in feet, the NYC skyline should be invisible behind 170 feet of curved Earth.



70) From Washington's Rock in New Jersey, at just a 400 foot elevation, it is possible on a clear day to see the skylines of both New York and Philadelphia in opposite directions at the same time covering a total distance of 120 miles! If Earth were a ball 25,000 miles in circumference, both of these skylines should be hidden behind over 800 feet of Earth's curvature.



71) It is often possible to see the Chicago skyline from sea-level 60 miles away across Lake Michigan. In 2015 after photographer Joshua Nowicki photographed

this phenomenon several news channels quickly claimed his picture to be a “superior mirage,” an atmospheric anomaly caused by temperature inversion. While these certainly do occur, the skyline in question was facing right-side up and clearly seen unlike a hazy illusory mirage, and on a ball-Earth 25,000 miles in circumference should be 2,400 feet below the horizon.

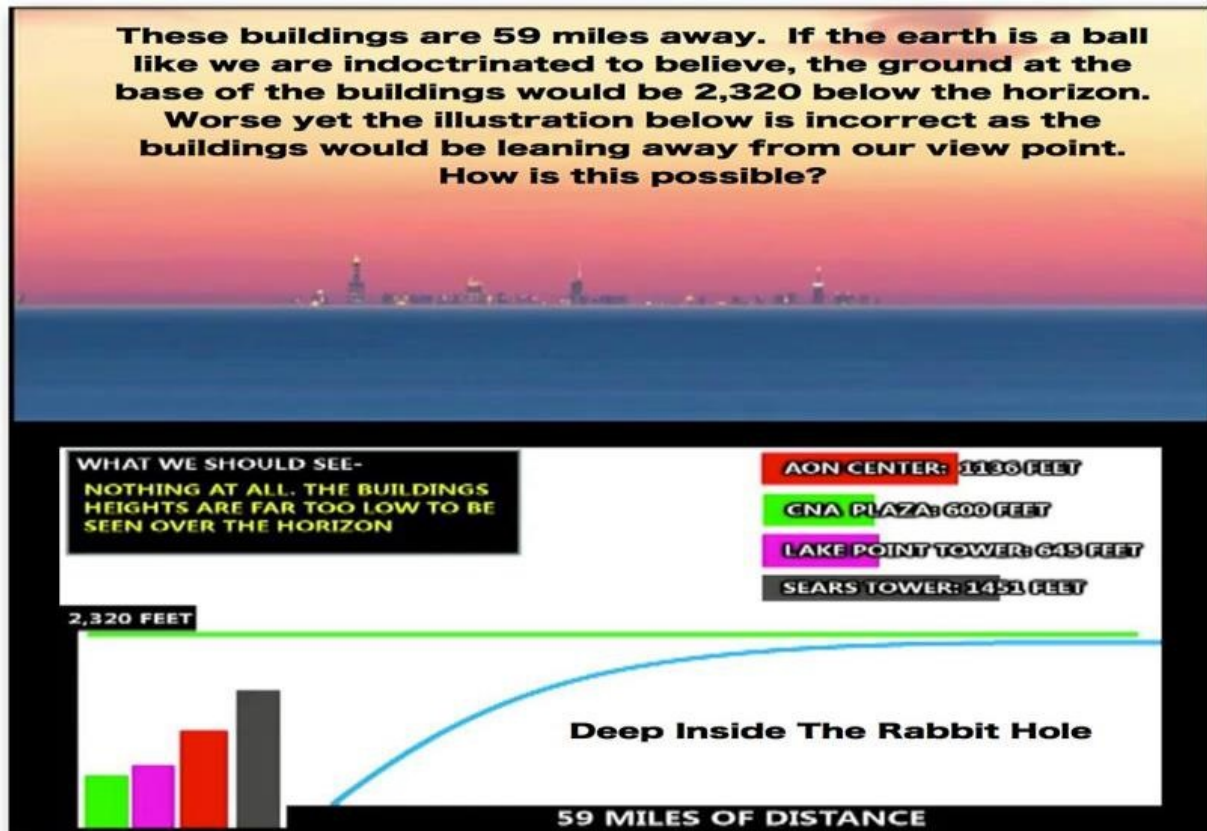

72) October 16, 1854 the Times newspaper reported the Queen’s visit to Great Grimsby from Hull recording they were able to see the 300 foot tall dock tower from 70 miles away. On a ball-Earth 25,000 miles in circumference, factoring their 10 foot elevation above the water and the tower’s 300 foot height, at 70 miles away the dock tower should have remained an entire 2,600 feet below the horizon.

73) In 1872 Capt. Gibson and crewmates, sailing the ship “Thomas Wood” from China to London, reported seeing the entirety of St. Helena Island on a clear day

from 75 miles away. Factoring in their height during measurement on a ball-Earth 25,000 miles in circumference, it was found the island should have been 3,650 feet below their line of sight.

74) From Genoa, Italy at a height of just 70 feet above sea-level, the island of Gorgona can often be seen 81 miles away. If Earth were a ball 25,000 miles in circumference, Gorgona should be hidden beyond 3,332 feet of curvature.



75) From Genoa, Italy at a height of just 70 feet above sea-level, the island of Corsica can often be seen 99 miles away. If Earth were a ball 25,000 miles in circumference, Corsica should fall 5,245 feet, almost an entire mile below the horizon.

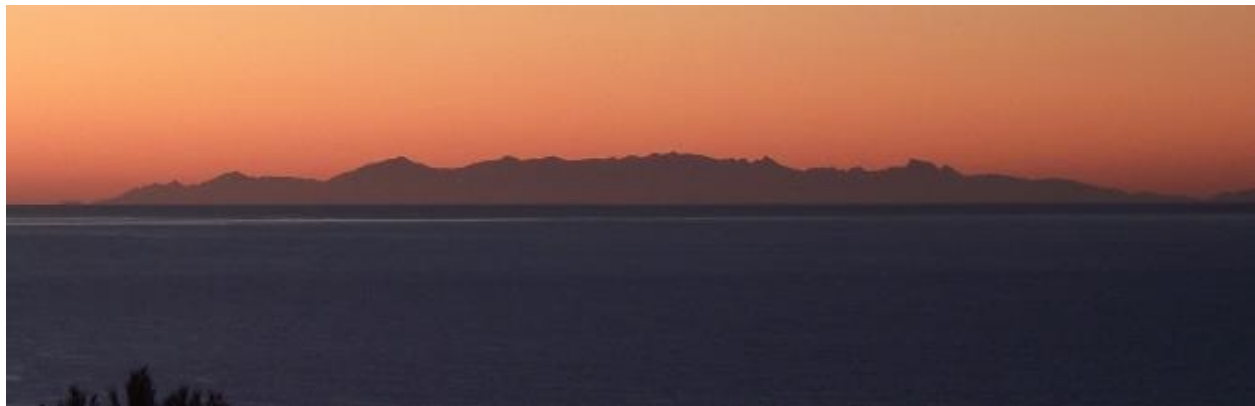

76) From Genoa, Italy 70 feet above sea-level, the island of Capraia 102 miles away can often be seen as well. If Earth were a ball 25,000 miles in circumference, Capraia should always remain hidden behind 5,605 feet, over a mile of supposed curvature.



77) Also from Genoa, on bright clear days, the island of Elba can be seen an incredible 125 miles away! If Earth were a ball 25,000 miles in circumference, Elba should be forever invisible behind 8,770 feet of curvature.



78) From Anchorage, Alaska at an elevation of 102 feet, on clear days Mount Foraker can be seen with the naked eye 120 miles away. If Earth were a ball 25,000 miles in circumference, Mount Foraker's 17,400 foot summit should be

leaning back away from the observer covered by 7,719 feet of curved Earth. In reality, however, the entire mountain can be quite easily seen standing straight from base to summit.



79) From Anchorage, Alaska at an elevation of 102 feet, on clear days Mount McKinley can be seen with the naked eye from 130 miles away. If Earth were a ball 25,000 miles in circumference, Mount McKinley's 20,320 foot summit should be leaning back away from the observer and almost half covered by 9,220 feet of curved Earth. In reality, however, the entire mountain can be quite easily seen standing straight from base to summit.

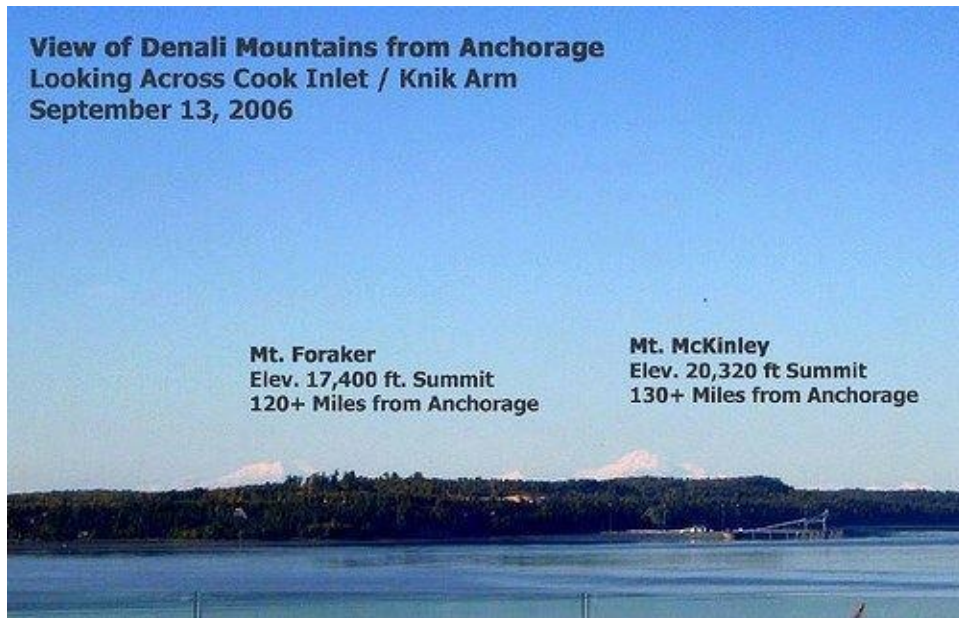

80) In Chambers' Journal, February 1895, a sailor near Mauritius in the Indian Ocean reported having seen a vessel which turned out to be an incredible 200 miles away! The incident caused much heated debate in nautical circles at the time, gaining further confirmation in Aden, Yemen where another witness reported seeing a missing Bombay steamer from 200 miles away. He correctly stated the precise appearance, location and direction of the steamer all later corroborated and confirmed correct by those onboard. Such sightings are absolutely inexplicable if the Earth were actually a ball 25,000 miles around, as ships 200 miles distant would have to fall approximately 5 miles below line of sight!

81) The distance from which various lighthouse lights around the world are visible at sea far exceeds what could be found on a ball-Earth 25,000 miles in circumference. For example, the Dunkerque Light in southern France at an altitude of 194 feet is visible from a boat (10 feet above sea-level) 28 miles away. Spherical trigonometry dictates that if the Earth was a globe with the given curvature of 8 inches per mile squared, this light should be hidden 190 feet below the horizon.



82) The Port Nicholson Light in New Zealand is 420 feet above sea-level and visible from 35 miles away where it should be 220 feet below the horizon.

83) The Egerö Light in Norway is 154 feet above high-water and visible from 28 statute miles where it should be 230 feet below the horizon.

84) The Light at Madras, on the Esplanade, is 132 feet high and visible from 28 miles away, where it should be 250 feet below the line of sight.

85) The Cordonan Light on the west coast of France is 207 feet high and visible from 31 miles away, where it should be 280 feet below the line of sight.

86) The light at Cape Bonavista, Newfoundland is 150 feet above sea-level and visible at 35 miles, where it should be 491 feet below the horizon.

87) The lighthouse steeple of St. Botolph's Parish Church in Boston is 290 feet

tall and visible from over 40 miles away, where it should be hidden a full 800 feet below the horizon!

88) The Isle of Wight lighthouse in England is 180 feet high and can be seen up to 42 miles away, a distance at which modern astronomers say the light should fall 996 feet below line of sight.

89) The Cape L'Agulhas lighthouse in South Africa is 33 feet high, 238 feet above sea level, and can be seen for over 50 miles. If the world were a globe, this light would fall 1,400 feet below an observer's line of sight.

90) The Statue of Liberty in New York stands 326 feet above sea level and on a clear day can be seen as far as 60 miles away. If the Earth were a globe, that would put Lady Liberty at an impossible 2,074 feet below the horizon.



91) The lighthouse at Port Said, Egypt, at an elevation of only 60 feet has been seen an astonishing 58 miles away, where, according to modern astronomy it should be 2,182 feet below the line of sight!

92) The Notre Dame Antwerp spire stands 403 feet high from the foot of the tower with Strasburg measuring 468 feet above sea level. With the aid of a telescope, ships can be distinguished on the horizon and captains declare they can see the cathedral spire from an amazing 150 miles away. If the Earth were a globe, however, at that distance the spire should be an entire mile, 5,280 feet below the horizon!



93) The St. George's Channel between Holyhead and Kingstown Harbor near Dublin is 60 miles across. When half-way across a ferry passenger will notice behind them the light on Holyhead pier as well as in front of them the Poolbeg light in Dublin Bay. The Holyhead Pier light is 44 feet high, while the Poolbeg lighthouse 68 feet, therefore a vessel in the middle of the channel, 30 miles from either side standing on a deck 24 feet above the water, can clearly see both lights. On a ball Earth 25,000 miles in circumference, however, both lights

should be hidden well below both horizons by over 300 feet!

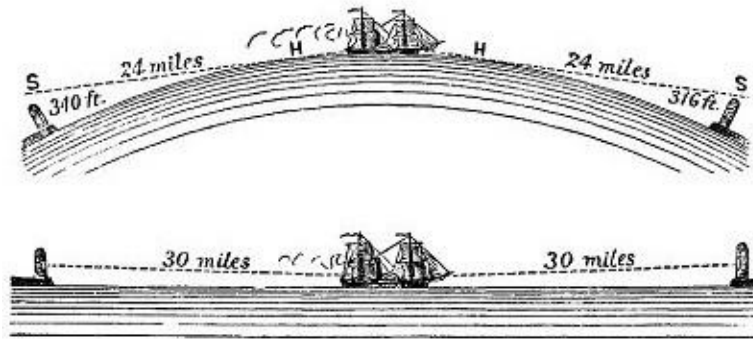

94) From the highland near Portsmouth Harbor in Hampshire, England looking across Spithead to the Isle of Wight, the entire base of the island, where water and land come together composes a perfectly straight line 22 statute miles long. According to the ball-Earth theory, the Isle of Wight should decline 80 feet from the center on each side to account for the necessary curvature. The cross-hairs of a good theodolite directed there, however, have repeatedly shown the land and water line to be perfectly level.

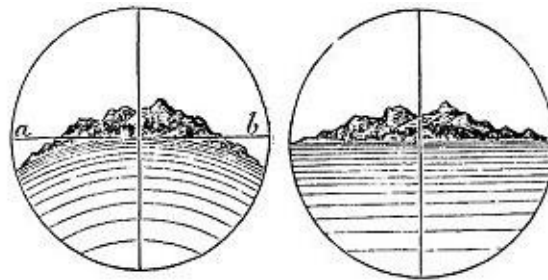

95) On a clear day from the highland near Douglas Harbor on the Isle of Man, the whole length of the coast of North Wales is often plainly visible to the naked eye. From the Point of Ayr at the mouth of the River Dee to Holyhead comprises a 50 mile stretch which has also been repeatedly found to be perfectly horizontal. If the Earth actually had curvature of 8 inches per mile squared, as NASA and modern astronomy claim, the 50 mile length of Welsh coast seen along the horizon in Liverpool Bay would have to decline from the center-point an easily

detectable 416 feet on each side!

96) From “[100 Proofs the Earth is Not a Globe](#)” (pages 12/13) by William Carpenter, “*If we take a journey down the Chesapeake Bay, by night, we shall see the ‘light’ exhibited at Sharpe’s Island for an hour before the steamer gets to it. We may take up a position on the deck so that the rail of the vessel’s side will be in a line with the ‘light’ and in the line of sight; and we shall find that in the whole journey the light won’t vary in the slightest degree in its apparent elevation. But, say that a distance of thirteen miles has been traversed, the astronomers’ theory of ‘curvature’ demands a difference (one way or the other!) in the apparent elevation of the light, of 112 feet 8 inches! Since, however, there is not a difference of 100 hair’s breadths, we have a plain proof that the water of the Chesapeake Bay is not curved, which is a proof that the Earth is not a globe.*”

97) NASA and modern astronomy say the Earth is a giant ball tilted back, wobbling and spinning 1,000 mph around its central axis, traveling 67,000 mph circles around the Sun, spiraling 500,000 mph around the Milky Way, while the entire galaxy rockets a ridiculous 670,000,000 mph through the Universe, with all of these motions originating from an alleged “Big Bang” cosmogenic explosion 14 billion years ago. That’s a grand total of 670,568,000 mph in several different directions we’re all supposedly speeding along at simultaneously, yet no one has ever seen, felt, heard, measured or proven a single one of these motions to exist whatsoever.

98) NASA and modern astronomy say Polaris, the North Pole star, is somewhere between 323-434 light years, or about 2 quadrillion miles, away from us! Firstly, note that is between 1,938,000,000,000,000 - 2,604,000,000,000,000 miles making a difference of 666,000,000,000,000 (over six hundred trillion) miles! If modern astronomy cannot even agree on the distance to stars within **hundreds of trillions** of miles, perhaps their “science” is flawed and their theory needs re-

examining. However, even granting them their obscurely distant stars, it is impossible for heliocentrists to explain how Polaris manages to always remain perfectly aligned straight above the North Pole throughout Earth's various alleged tilting, wobbling, rotating and revolving motions.



99) Viewed from a ball-Earth, Polaris, situated directly over the North Pole, should not be visible anywhere in the Southern hemisphere. For Polaris to be seen from the Southern hemisphere of a globular Earth, the observer would have to be somehow looking “through the globe,” and miles of land and sea would have to be transparent. Polaris can be seen, however, up to over 20 degrees South latitude.

100) If Earth were a ball, the Southern Cross and other Southern constellations would all be visible at the same time from every longitude on the same latitude as is the case in the North with Polaris and its surrounding constellations. Ursa

Major/Minor and many others can be seen from every Northern meridian simultaneously whereas in the South, constellations like the Southern Cross cannot. This proves the Southern hemisphere is not “turned under” as in the ball-Earth model, but simply stretching further outwards away from the Northern center-point as in the flat Earth model.

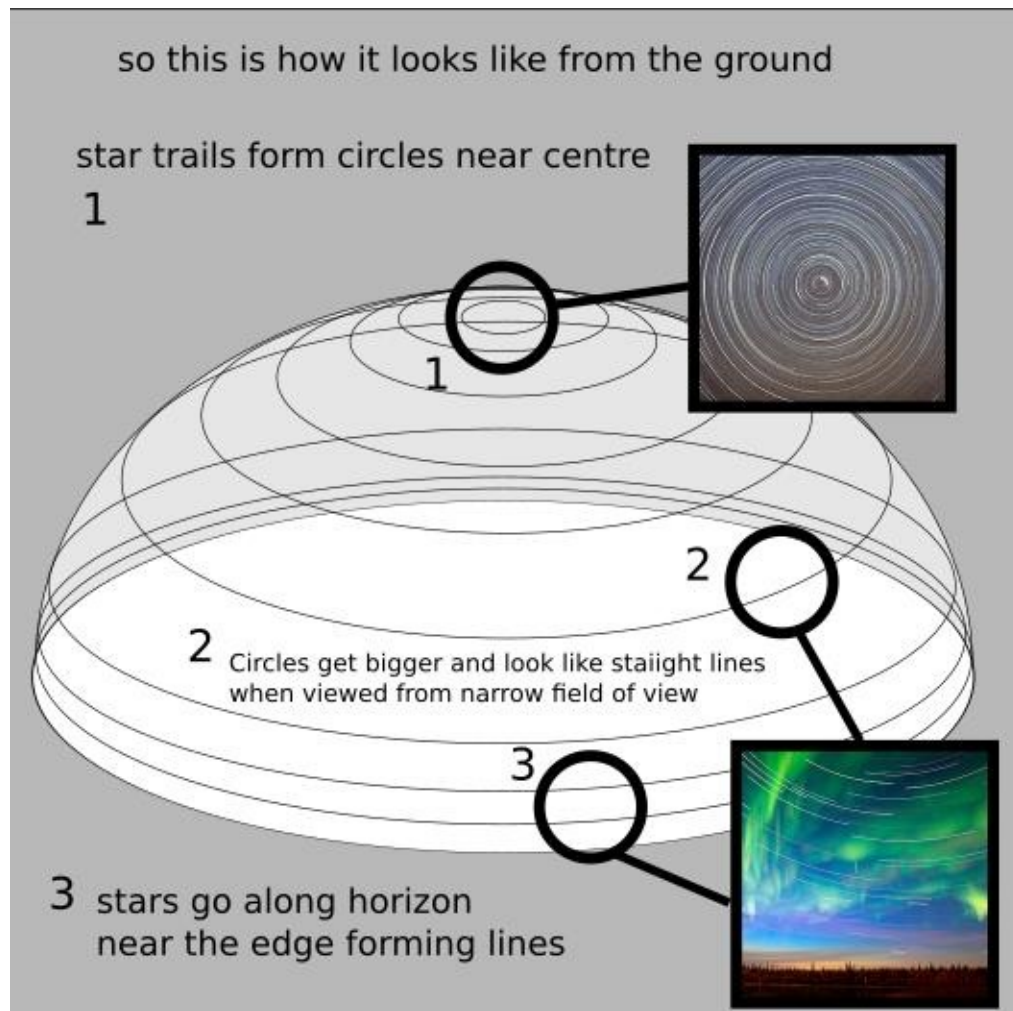

101) Sigma Octantis is claimed to be a Southern central pole star similar to Polaris, around which the Southern hemisphere stars all rotate around the opposite direction. Unlike Polaris, however, Sigma Octantis can NOT be seen simultaneously from every point along the same latitude, it is NOT central but allegedly 1 degree off-center, it is NOT motionless, and in fact cannot be seen at all using publicly available telescopes! There is legitimate speculation regarding

whether Sigma Octantis even exists. Either way, the direction in which stars move overhead is based on perspective and the exact direction you're facing, not which hemisphere you are in.

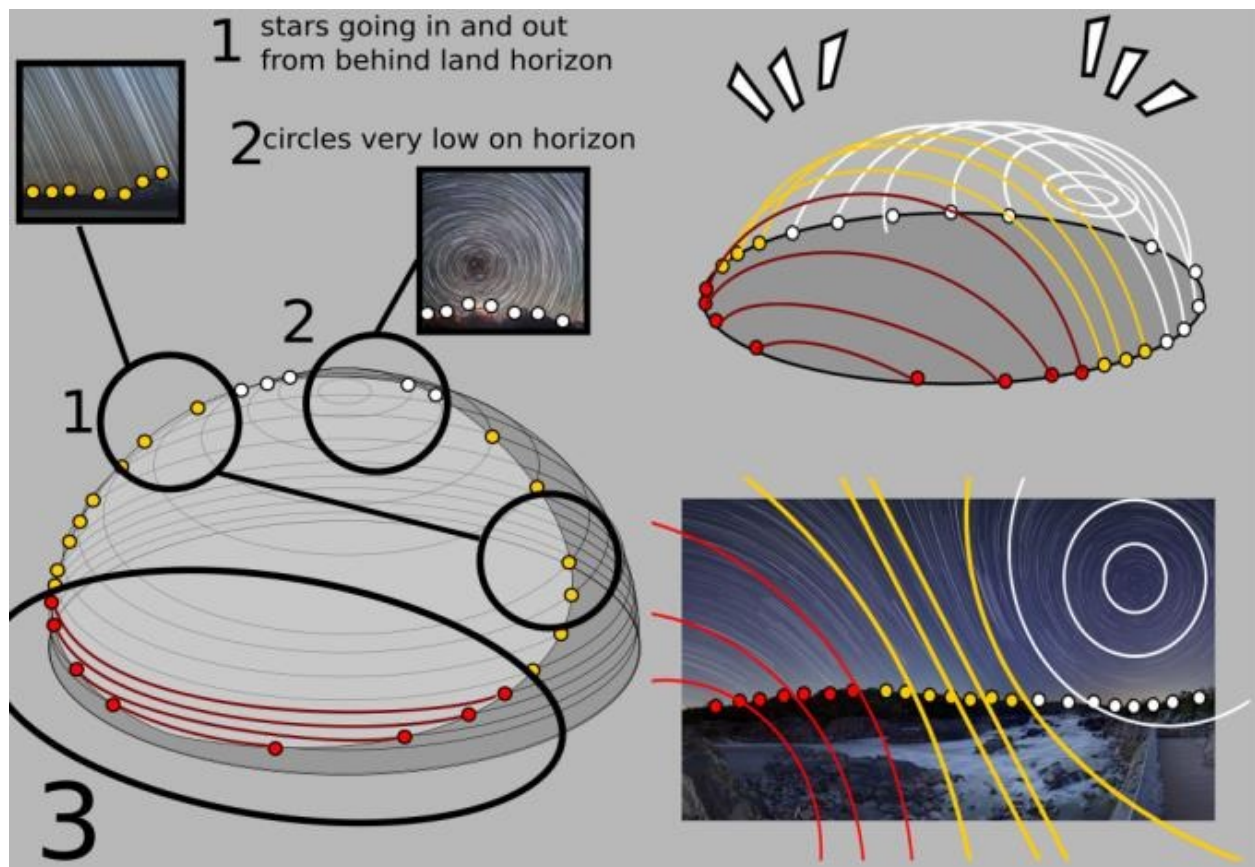

102) Some heliocentrists have tried to suggest that the Pole Star's gradual declination overhead as an observer travels southwards is proof of a globular Earth. Far from it, the declination of the Pole Star or any other object is simply a result of the Law of Perspective on plane (flat) surfaces. The Law of Perspective dictates that the angle and height at which an object is seen diminishes the farther one recedes from the object, until at a certain point the line of sight and the seemingly uprising surface of the Earth converges to a vanishing point (i.e. the horizon line) beyond which the object is invisible. In the ball-Earth model the horizon is claimed to be the curvature of the Earth, whereas in reality, the horizon is known to be simply the vanishing line of perspective based on the

strength of your eyes, instruments, weather and altitude.

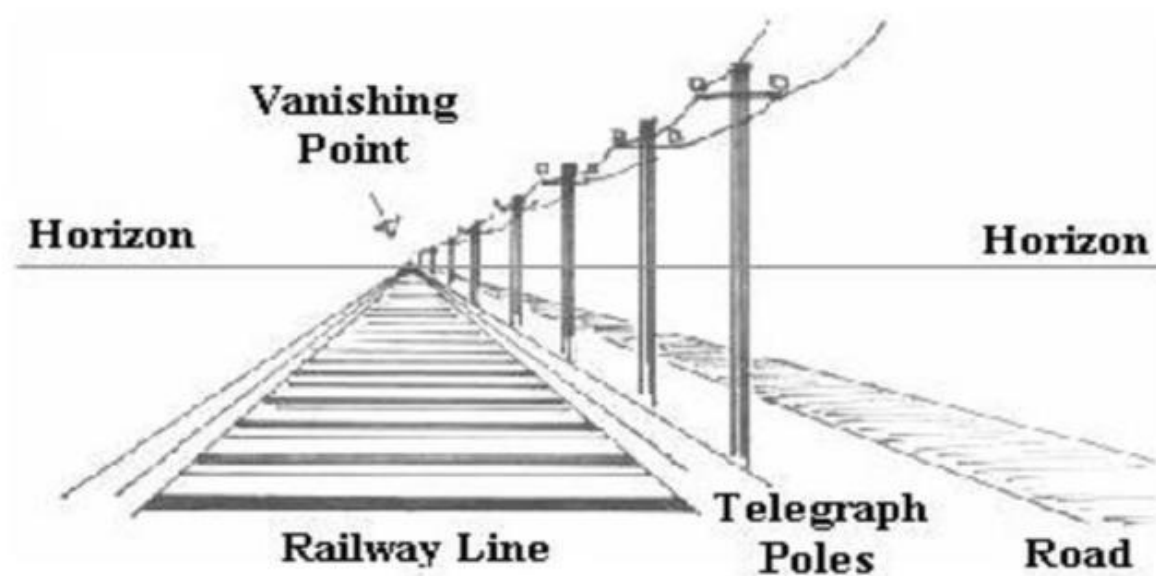

103) There are several constellations which can be seen from far greater distances over the face of the Earth than should be possible if the world were a rotating, revolving, wobbling ball. For instance, Ursa Major, very close to Polaris, can be seen from 90 degrees North latitude (the North Pole) all the way down to 30 degrees South latitude. For this to be possible on a ball-Earth the Southern observers would have to be seeing through hundreds or thousands of miles of bulging Earth to the Northern sky.

104) The constellation Vulpecula can be seen from 90 degrees North latitude, all the way to 55 degrees South latitude. Taurus, Pisces and Leo can be seen from 90 degrees North all the way to 65 degrees South. An observer on a ball-Earth, regardless of any tilt or inclination, should not logically be able to see this far.

105) Aquarius and Libra can be seen from 65 degrees North to 90 degrees South! The constellation Virgo is visible from 80 degrees North down to 80 degrees South, and Orion can be seen from 85 degrees North all the way to 75

degrees South latitude! These are all only possible because the “hemispheres” are not spheres at all but concentric circles of latitude extending outwards from the central North Pole with the stars rotating over and around.



106) The so-called “South Pole” is simply an arbitrary point along the Antarctic ice marked with a red and white barbershop pole topped with a metal ball-Earth. This ceremonial South Pole is admittedly and provably NOT the actual South Pole, however, because the actual South Pole could be demonstrably confirmed with the aid of a compass showing North to be 360 degrees around the observer. Since this feat has never been achieved, the model remains pure theory, along with the establishment’s excuse that the geomagnetic poles supposedly constantly move around making verification of their claims impossible.

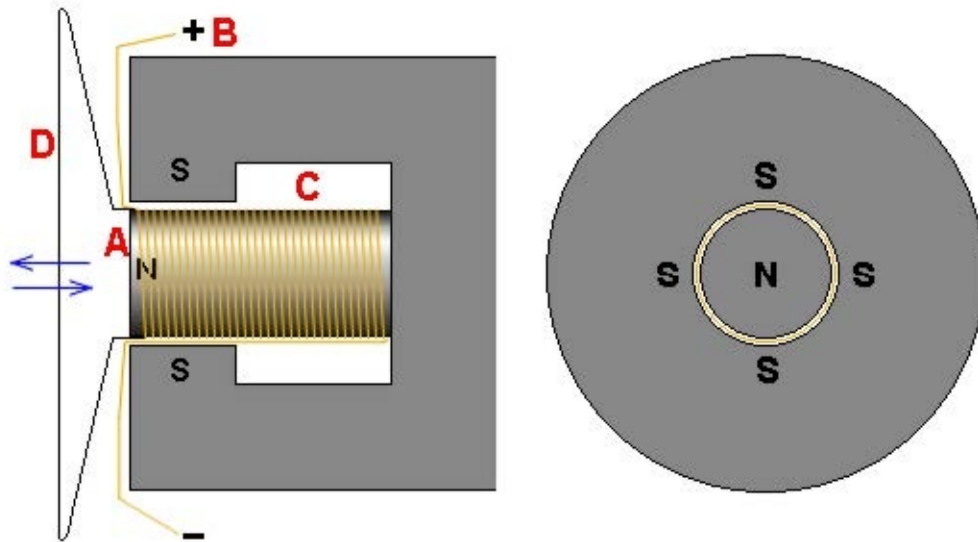

107) Ring magnets of the kind found in loudspeakers have a central North pole with the opposite “South” pole actually being all points along the outer circumference. This perfectly demonstrates the magnetism of our flat Earth, whereas the alleged source of magnetism in the ball-Earth model is emitted from a hypothetical molten magnetic core in the center of the ball which they claim conveniently causes both poles to constantly move thus evading independent verification at their two “ceremonial poles.” In reality the deepest drilling operation in history, the Russian [Kola Superdeep borehole](#), managed to get only 8 miles down, so the entire ball-Earth model taught in schools showing a crust, outer-mantle, inner-mantle, outer-core and inner-core layers are all purely speculation as we have never penetrated through beyond the crust.

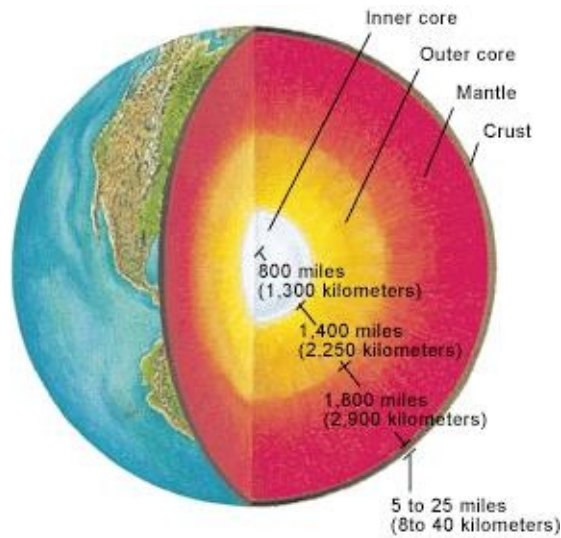

108) The mariner’s compass is an impossible and non-sensical instrument for use on a ball-Earth. It simultaneously points North and South over a flat surface, yet claims to be pin-pointing two constantly moving geomagnetic poles at opposite ends of a spinning sphere originating from a hypothetical molten metal core. If compass needles were actually drawn to the North pole of a globe, the opposing “South” needle would actually be pointing up and off into outer-space.



109) There are no fixed “East” or “West” points just as there is no fixed “South.” The North central Pole is the only proven fixed point on our flat Earth, with South being all straight lines outwards from the pole, East and West being concentric circles at constant right angles 90 degrees from the pole. A westerly

circumnavigation of Earth is thus going around with Polaris continually on your right, while an easterly circumnavigation is going around with Polaris always at your left.

110) Magellan and others' East/West circumnavigations of Earth are often quoted as proof of the ball model. In actual fact, however, sailing or flying at right angles to the North pole and eventually returning to one's original location is no more difficult or mysterious than doing so on a globe. Just as an architect's compass can place its center-point on a flat piece of paper and trace a circle either way around the "pole," so can a ship or plane circumnavigate a flatEarth.

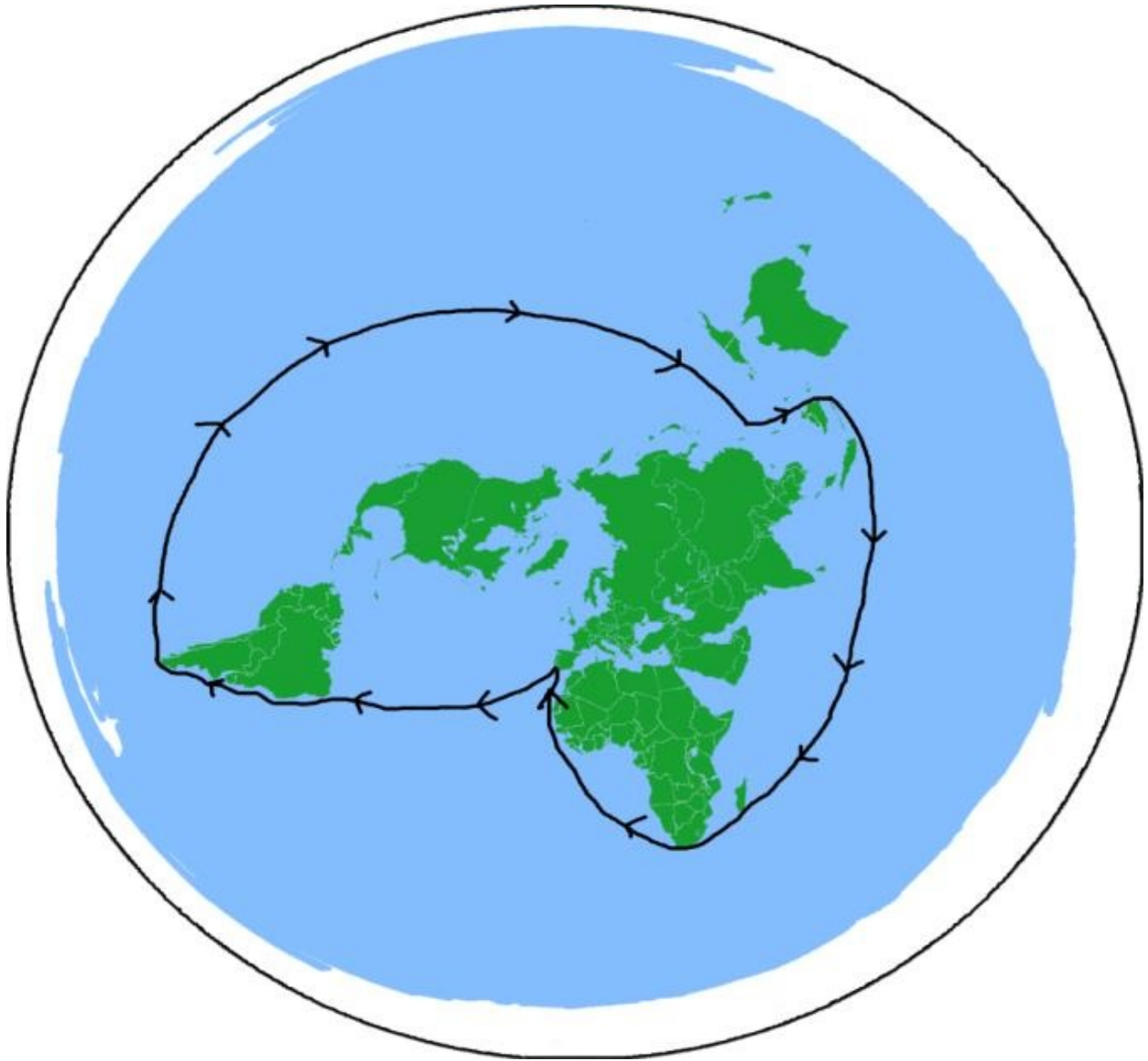

111) Since the North Pole and Antarctica are covered in ice and guarded “no-fly” zones, no ships or planes have ever been known to circumnavigate the Earth in North/South directions. The only kind of circumnavigation which could not happen on a flatEarth is North/Southbound, which is likely the very reason for the heavily-enforced flight restrictions. The fact that there has yet to be a single verified North/South circumnavigation of Earth serves as standing proof the world is not a ball.

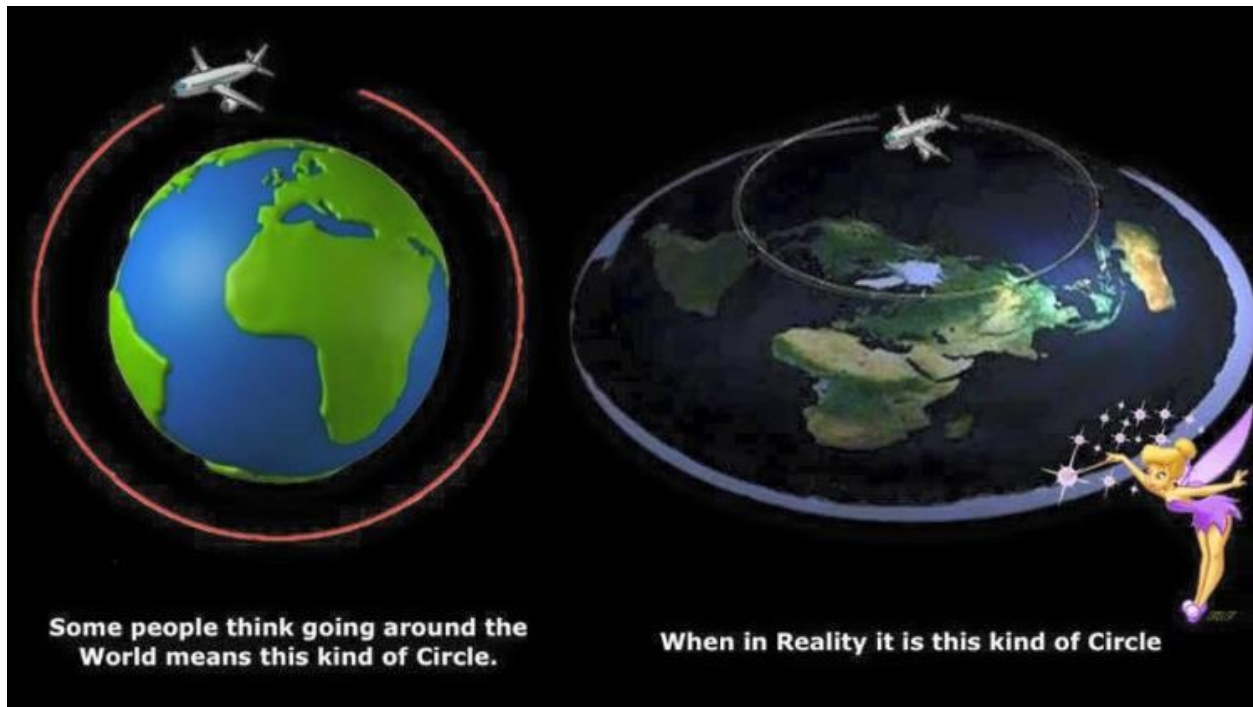

112) The Sun brings noon to every time-zone as it passes directly overhead every 15 degree demarcation point, 24 times per day in its circular path over and around the Earth. If time-zones were instead caused by the uniform spinning of the ball-Earth around the Sun, every 6 months as Earth found itself on the opposite side of the Sun, clocks all over Earth would have to flip 12 hours, day would be night and night would be day.

113) The idea that people are standing, ships are sailing and planes are flying upside down on certain parts of Earth while others tilted at 90 degrees and all other impossible angles is complete absurdity. The idea that a man digging a hole straight down could eventually reach sky on the other side is ludicrous. Common sense tells every free-thinking person correctly that there truly is an “up” and “down” in nature, unlike the “everything is relative” rhetoric of the Newtonian/Einsteinian paradigm.



114) Quoting, “On the False Wisdom of the Philosophers” by Lactantius, “A sphere where people on the other side live with their feet above their heads, where rain, snow and hail fall upwards, where trees and crops grow upside-down and the sky is lower than the ground? The ancient wonder of the hanging gardens of Babylon dwindle into nothing in comparison to the fields, seas, towns and mountains that pagan philosophers believe to be hanging from the earth without support!”



115) The existing laws of density and buoyancy perfectly explained the physics

of falling objects long before knighted Freemason “Sir” Isaac Newton bestowed his theory of “gravity” upon the world. It is a fact that objects placed in denser mediums rise up while objects placed in less dense mediums sink down. To fit with the heliocentric model which has no up or down, Newton instead claimed objects are attracted to large masses and fall towards the center. Not a single experiment in history, however, has shown an object massive enough to, by virtue of its mass alone, cause other smaller masses to be attracted to it as Newton claims “gravity” does with Earth, the Sun, Moon, Stars and Planets.



116) There has also never been a single experiment in history showing an object massive enough to, by virtue of its mass alone, cause another smaller mass to orbit around it. The magic theory of gravity allows for oceans, buildings and people to remain forever stuck to the underside of a spinning ball while simultaneously causing objects like the Moon and satellites to remain locked in

perpetual circular orbits around the Earth. If these were both true then people should be able to jump up and start orbiting circles around the Earth, or the Moon should have long ago been sucked into the Earth. Neither of these theories have ever been experimentally verified and their alleged results are mutually exclusive.



117) Newton also theorized and it is now commonly taught that the Earth's ocean tides are caused by gravitational lunar attraction. If the Moon is only 2,160 miles in diameter and the Earth 8,000 miles, however, using their own math and "law," it follows that the Earth is 87 times more massive and therefore the larger object should attract the smaller to it, and not the other way around. If the Earth's greater gravity is what keeps the Moon in orbit, it is impossible for the Moon's lesser gravity to supersede the Earth's gravity, especially at Earth's sea-level, where its gravitational attraction would even further out-trump the Moon's. And if the Moon's gravity truly did supersede the Earth's causing the tides to be drawn towards it, there should be nothing to stop them from continuing onwards and upwards towards their great attractor.

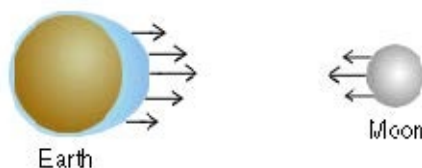

118) Furthermore, the velocity and path of the Moon are uniform and should therefore exert a uniform influence on the Earth's tides, when in actuality the

Earth's tides vary greatly and do not follow the Moon. Earth's lakes, ponds, marshes and other inland bodies of water also inexplicably remain forever outside the Moon's gravitational grasp! If "gravity" was truly drawing Earth's oceans up to it, all lakes, ponds and other bodies of standing water should certainly have tides as well.

119) It is claimed that the other planets are spheres and so therefore Earth must also be a sphere. Firstly, Earth is a "plane" not a "planet," so the shape of these "planets" in the sky have no bearing on the shape of the Earth beneath our feet. Secondly, these "planets" have been known for thousands of years around the world as the "wandering stars" since they differ from the other fixed stars in their relative motions only. When looked at with an unprejudiced naked-eye or through a telescope, the fixed and wandering stars appear as luminous discs of light, NOT spherical terra firma. The pictures and videos shown by NASA of spherical terra firma planets are all clearly fake computer-generated images, and NOT photographs.



120) The etymology of the word "planet" actually comes from late Old English *planete*, from Old French *planete* (Modern French *planète*), from Latin *planeta*,

from Greek *planetes*, from (*asteres*) *planetai* “wandering (stars),” from *planasthai* “to wander,” of unknown origin, possibly from PIE **pele-* “flat, to spread” or notion of “spread out.” And “plane” (n) “flat surface,” c. 1600, from Latin *planum* “flat surface, plane, level, plain,” *planus* “flat, level, even, plain, clear.” They just added a “t” to our Earth plane and everyone bought it.

121) When you observe the Sun and Moon you see two equally-sized equidistant circles tracing similar paths at similar speeds around a flat, stationary Earth. The “experts” at NASA, however, claim your common sense every day experience is false on all counts! To begin with, they say the Earth is not flat but a big ball; not stationary but spinning around 19 miles per second; they say the Sun does not revolve around the Earth as it appears, but Earth revolves around the Sun; the Moon, on the other hand, does revolve around the Earth, though not East to West as it appears, rather West to East; and the Sun is actually 400 times larger than the Moon and 400 times farther away! You can clearly see they are the same size and distance, you can see the Earth is flat, you can feel the Earth is stationary, but according to the gospel of modern astronomy, you are wrong and a simpleton worthy of endless ridicule if you dare to trust your own eyes and experience.



122) Quoting Allen Daves, “*If the Government or NASA had said to you that the Earth is stationary, imagine that. And then imagine we are trying to convince people that 'no, no it's not stationary, it's moving forward at 32 times rifle bullet speed and spinning at 1,000 miles per hour.'* We would be laughed at! We would have so many people telling us 'you are crazy, the Earth is not moving!' We

would be ridiculed for having no scientific backing for this convoluted moving Earth theory. And not only that but then people would say, 'oh then how do you explain a fixed, calm atmosphere and the Sun's observable movement, how do you explain that?' Imagine saying to people, 'no, no, the atmosphere is moving also but is somehow magically velcroed to the moving-Earth. The reason is not simply because the Earth is stationary.' So what we are actually doing is what makes sense. We are saying that the moving-Earth theory is nonsense. The stationary-Earth theory makes sense and we are being ridiculed. You've got to picture it being the other way around to realize just how RIDICULOUS this situation is. This theory from the Government and NASA that the Earth is rotating and orbiting and leaning over and wobbling is absolute nonsense and yet people are clinging to it, tightly, like a teddy bear. They just can't bring themselves to face the possibility that the Earth is stationary though ALL the evidence shows it: we feel no movement, the atmosphere hasn't been blown away, we see the Sun move from East-to-West, everything can be explained by a motionless Earth without bringing in all these assumptions to cover up previous assumptions gone bad.”

123) Heliocentrists’ astronomical figures always sound perfectly precise, but they have historically been notorious for regularly and drastically changing them to suit their various models. For instance, in his time Copernicus calculated the Sun’s distance from Earth to be 3,391,200 miles. The next century Johannes Kepler decided it was actually 12,376,800 miles away. Issac Newton once said, “It matters not whether we reckon it 28 or 54 million miles distant for either would do just as well!” How scientific! Benjamin Martin calculated between 81 and 82 million miles, Thomas Dilworth claimed 93,726,900 miles, John Hind stated positively 95,298,260 miles, Benjamin Gould said more than 96 million miles, and Christian Mayer thought it was more than 104 million! Flat-Earthers throughout the ages, conversely, have used sextants and plane trigonometry to make such calculations and found the Sun and Moon both to be only about 32

miles in diameter and less than a few thousand miles from Earth.

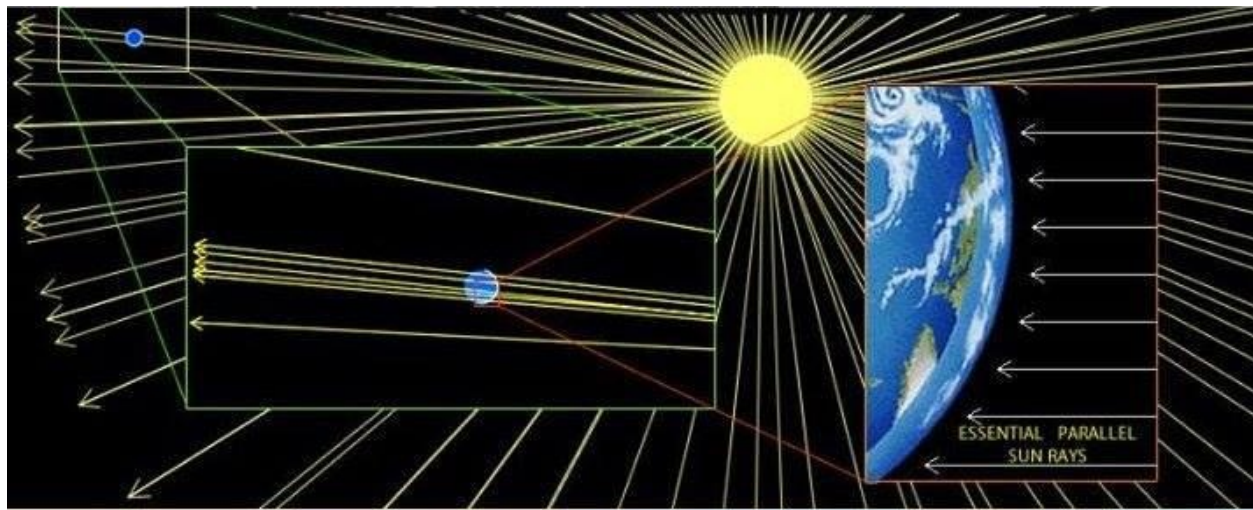

124) Amateur balloon footage taken above the clouds has provided stunning visual proof that the Sun cannot be millions of miles away. In several shots you can see a clear hot-spot reflecting on the clouds directly below the Sun's spotlight-like influence. If the Sun were actually millions of miles away such a small, localized hot-spot could not occur.



The Sun is clearly NOT 93 million miles away. You can see a hot-spot directly underneath it, proving it is very close.

125) Another proof the Sun is not millions of miles away is found by tracing the angle of sun-rays back to their source above the clouds. There are thousands of pictures showing how sunlight comes down through cloud-cover at a variance of converging angles. The area of convergence is of course the Sun, and is clearly NOT millions of miles away, but rather relatively close to Earth just above the clouds.

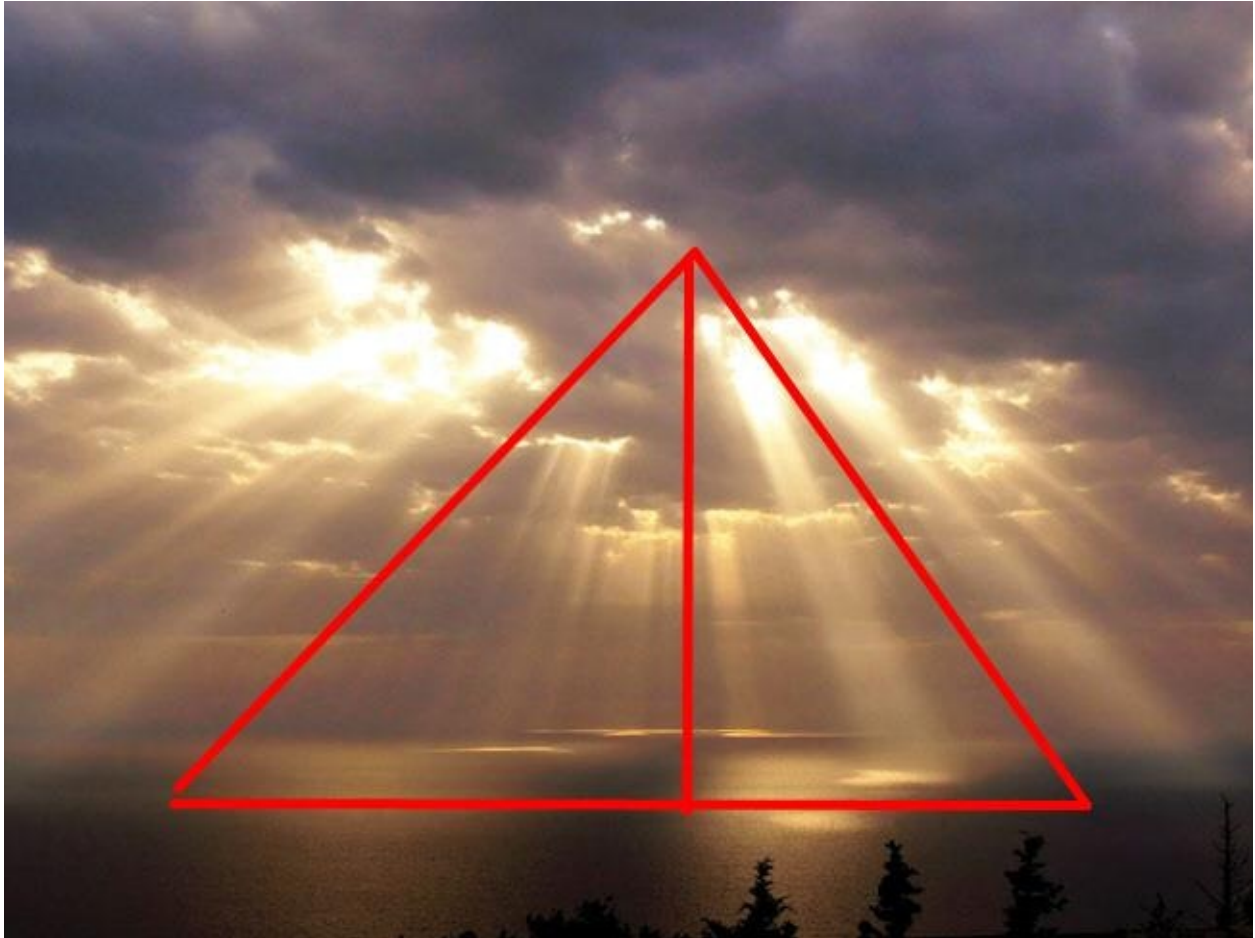

126) The Sun’s annual journey from tropic to tropic, solstice to solstice, is what determines the length and character of days, nights and seasons. This is why equatorial regions experience almost year-round summer and heat while higher latitudes North and especially South experience more distinct seasons with harsh winters. The heliocentric model claims seasons change based on the ball-Earth’s alleged “axial tilt” and “elliptical orbit” around the Sun, yet their flawed current model places us closest to the Sun (91,400,000 miles) in January when its actually winter, and farthest from the Sun (94,500,000 miles) in July when its actually summer throughout most of the Earth.

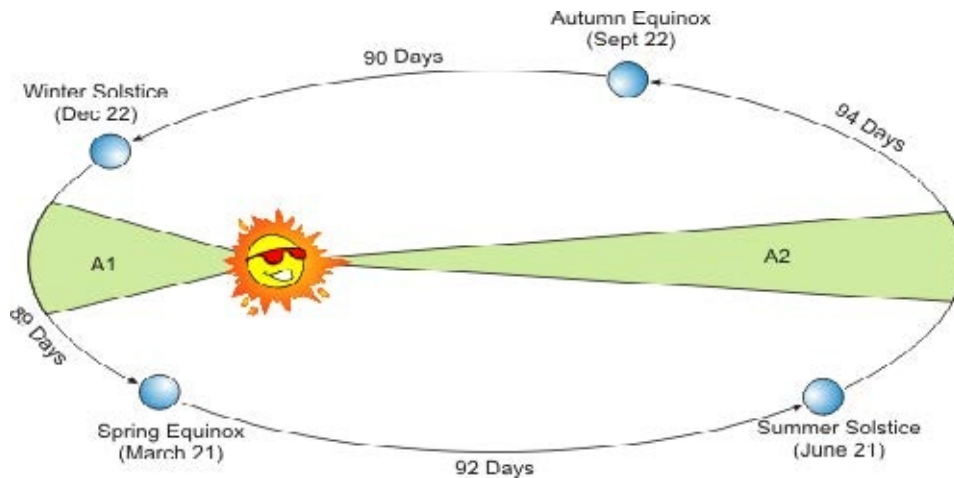

127) The fact that the Sun and Moon’s reflections on water always form a straight line path from the horizon to the observer proves the Earth is not a ball. If Earth’s surface was curved it would be impossible for the reflected light to curve over the ball from horizon to observer.



128) There are huge centuries-old stone sundials and moondials all over the world which still tell the time now down to the minute as perfectly as the day they were made. If the Earth, Sun and Moon were truly subject to the number of

contradictory revolving, rotating, wobbling and spiraling motions claimed by modern astronomy, it would be impossible for these monuments to so accurately tell time without constant adjustment.

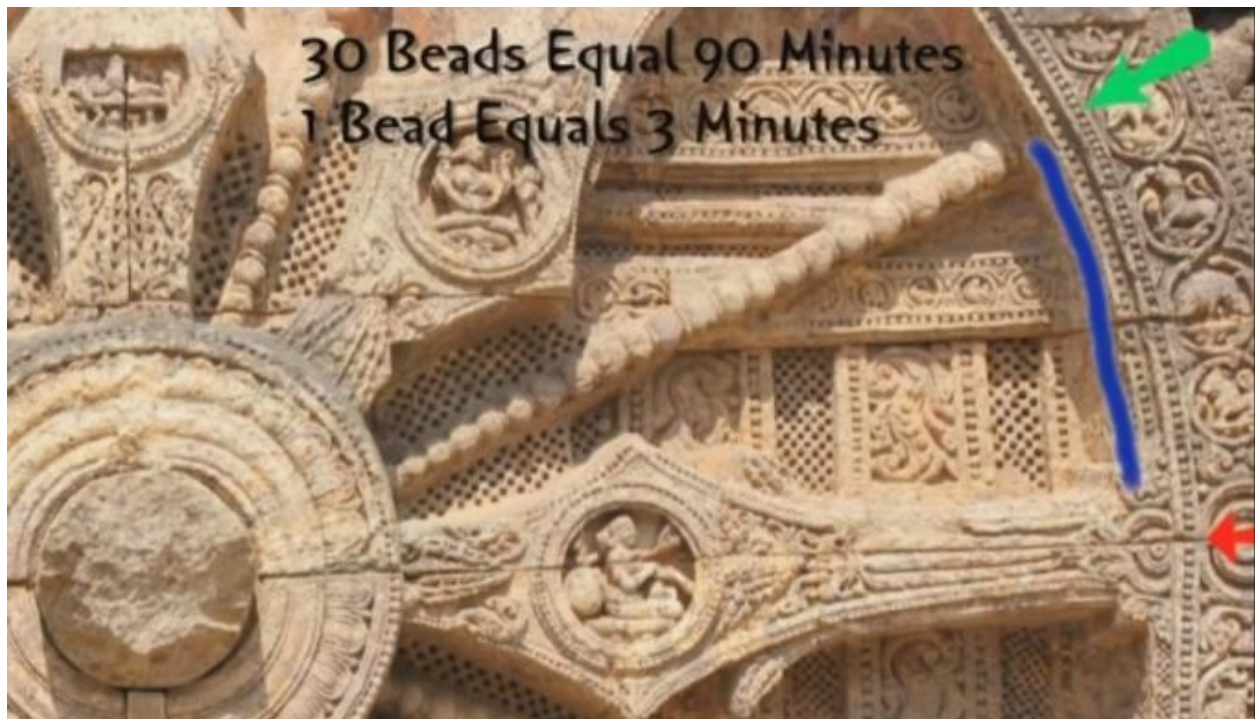

129) To quote William Carpenter ([Earth is Not a Globe](#), page 25), “Why, in the name of common sense, should observers have to fix their telescopes on solid stone bases so that they should not move a hair's-breadth, - if the Earth on which they fix them moves at the rate of nineteen miles in a second? Indeed, to believe that ‘six thousand million million million tons’ is ‘rolling, surging, flying, darting on through space for ever’ with a velocity compared with which a shot from a cannon is a ‘very slow coach,’ with such unerring accuracy that a telescope fixed on granite pillars in an observatory will not enable a lynx-eyed astronomer to detect a variation in its onward motion of the thousandth part of a hair's-breadth is to conceive a miracle compared with which all the miracles on record put together would sink into utter insignificance. Since we can, (in middle north latitudes), see the North Star, on looking out of a window that faces it - and out of the very same corner of the very same pane of glass in the very same

window - all the year round, it is proof enough for any man in his senses that we have made no motion at all and that the Earth is not a globe.”

130) From “[Earth Not a Globe!](#)” (page 68) by Samuel Rowbotham, “Take two carefully-bored metallic tubes, not less than six feet in length, and place them one yard asunder, on the opposite sides of a wooden frame, or a solid block of wood or stone: so adjust them that their centres or axes of vision shall be perfectly parallel to each other. Now, direct them to the plane of some notable fixed star, a few seconds previous to its meridian time. Let an observer be stationed at each tube and the moment the star appears in the first tube let a loud knock or other signal be given, to be repeated by the observer at the second tube when he first sees the same star. A distinct period of time will elapse between the signals given. The signals will follow each other in very rapid succession, but still, the time between is sufficient to show that the same star is not visible at the same moment by two parallel lines of sight when only one yard asunder. A slight inclination of the second tube towards the first tube would be required for the star to be seen through both tubes at the same instant. Let the tubes remain in their position for six months; at the end of which time the same observation or experiment will produce the same results--the star will be visible at the same meridian time, without the slightest alteration being required in the direction of the tubes: from which it is concluded that if the earth had moved one single yard in an orbit through space, there would at least be observed the slight inclination of the tube which the difference in position of one yard had previously required. But as no such difference in the direction of the tube is required, **the conclusion is unavoidable, that in six months a given meridian upon the earth's surface does not move a single yard, and therefore, that the earth has not the slightest degree of orbital motion.**”

131) NASA and modern astronomy maintain that the Moon is a solid, spherical, Earth-like habitation which man has actually flown to and set foot on. They

claim the Moon is a non-luminescent planetoid which receives and reflects all its light from the Sun. The reality is, however, that the Moon is observably not a solid body, it is clearly circular, but not spherical, and not in any way an Earth-like planetoid which humans could set foot on. In fact, the Moon has been proven largely transparent and completely self-luminescent, shining with its own unique light.



132) The Sun's light is golden, warm, drying, preservative and antiseptic, while the Moon's light is silver, cool, damp, putrefying and septic. The Sun's rays decrease the combustion of a bonfire, while the Moon's rays increase combustion. Plant and animal substances exposed to sunlight quickly dry, shrink, coagulate, and lose the tendency to decompose and putrify; grapes and other fruits become solid, partially candied and preserved like raisins, dates, and

prunes; animal flesh coagulates, loses its volatile gaseous constituents, becomes firm, dry, and slow to decay. When exposed to moonlight, however, plant and animal substances tend to show symptoms of putrefaction and decay. This proves that Sun and Moon light are different, unique, and opposites as they are in the geocentric flat model.



133) In direct sunlight a thermometer will read higher than another thermometer placed in the shade, but in full, direct moonlight a thermometer will read lower than another placed in the shade. If the Sun's light is collected in a large lens and thrown to a focus point it can create significant heat, while the Moon's light collected similarly creates no heat. In the "*Lancet Medical Journal*," from March 14th, 1856, particulars are given of several experiments which proved the Moon's rays when concentrated can actually reduce the temperature upon a thermometer more than eight degrees. So sunlight and moonlight clearly have altogether different properties.

134) Furthermore the Moon itself cannot physically be both a spherical body and a reflector of the Sun's light. Reflectors must be flat or concave for light rays to have any angle of incidence; If a reflector's surface is convex then every ray of light points in a direct line with the radius perpendicular to the surface resulting in no reflection.

135) Not only is the Moon clearly self-luminescent, shining its own unique light, but it is also largely transparent. When the waxing or waning Moon is visible during the day it is possible to see the blue sky right through the Moon. And on a clear night, during a waxing or waning cycle, it is even possible to occasionally see stars and “planets” directly through the surface of the Moon! The Royal Astronomical Society has on record many such occurrences throughout history which all defy the heliocentric model.



136) Many people think that modern astronomy’s ability to accurately predict lunar and solar eclipses is a result and proof positive of the heliocentric theory of the universe. The fact of the matter however is that eclipses have been accurately predicted by cultures worldwide for thousands of years before the “heliocentric ball-Earth” was even a glimmer in Copernicus’ imagination. Ptolemy in the 1st century A.D. accurately predicted eclipses for six hundred years on the basis of a flat, stationary Earth with equal precision as anyone living today. All the way

back in 600 B.C. Thales accurately predicted an eclipse which ended the war between the Medes and Lydians. Eclipses happen regularly with precision in 18 year cycles, so regardless of geocentric or heliocentric, flat or globe Earth cosmologies, eclipses can be accurately calculated independent of such factors.



137) Another assumption and supposed proof of Earth's shape, heliocentrists claim that lunar eclipses are caused by the shadow of the ball-Earth occulting the Moon. They claim the Sun, Earth, and Moon spheres perfectly align like three billiard balls in a row so that the Sun's light casts the Earth's shadow onto the Moon. Unfortunately for heliocentrists, this explanation is rendered completely invalid due to the fact that lunar eclipses have happened and continue to happen regularly when both the Sun and Moon are still visible together above the horizon! For the Sun's light to be casting Earth's shadow onto the Moon, the three bodies must be aligned in a straight 180 degree syzygy, but as early as the time of Pliny, there are records of lunar eclipses happening while both the Sun and Moon are visible in the sky. Therefore the eclipsor of the Moon cannot be the Earth/Earth's shadow and some other explanation must be sought.

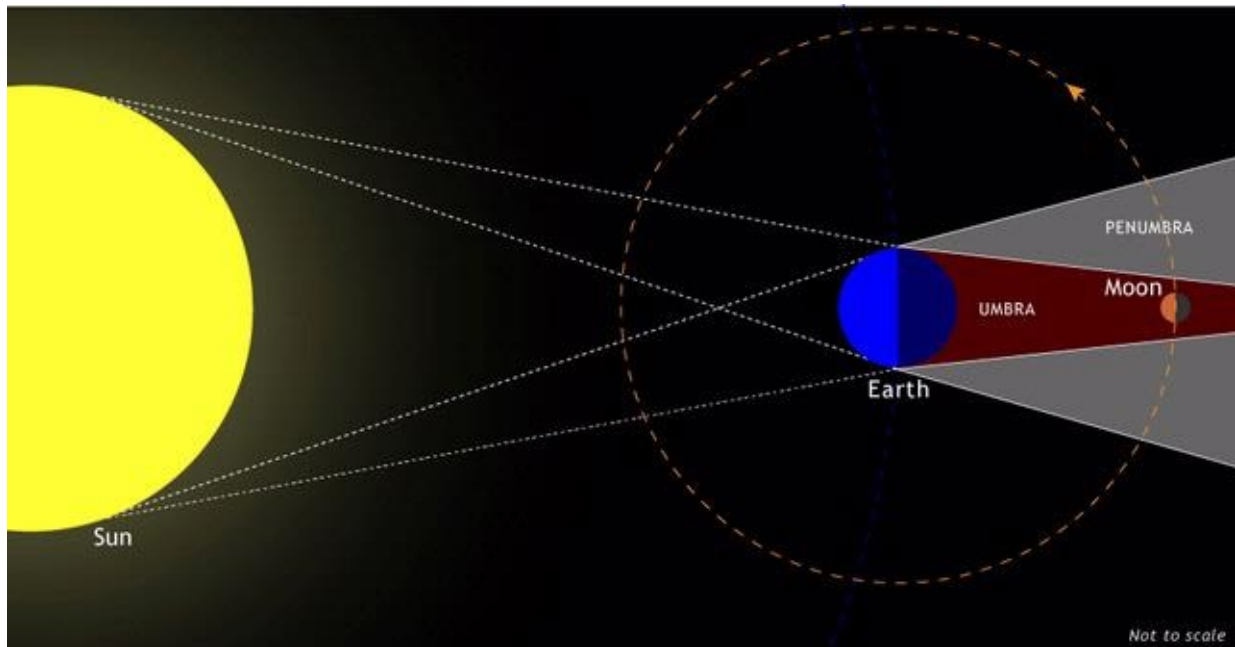

138) Another favorite “proof” of ball-Earthers is the appearance from an observer on shore of ships’ hulls being obfuscated by the water and disappearing from view when sailing away towards the horizon. Their claim is that ships’ hulls disappear before their mast-heads because the ship is beginning its declination around the convex curvature of the ball-Earth. Once again, however, their hasty conclusion is drawn from a faulty premise, namely that only on a ball-Earth could this phenomenon occur. The fact of the matter is that the Law of Perspective on plane surfaces dictates and necessitates the exact same occurrence. For example a girl wearing a dress walking away towards the horizon will appear to sink into the Earth the farther away she walks. Her feet will disappear from view first and the distance between the ground and the bottom of her dress will gradually diminish until after about half a mile it seems like her dress is touching the ground as she walks on invisible legs. Such is the case on plane surfaces, the lowest parts of objects receding from a given point of observation necessarily disappear before the highest.



139) Not only is the disappearance of ship's hulls explained by the Law of Perspective on flat surfaces, it is proven undeniably true with the aid of a good telescope. If you watch a ship sailing away into the horizon with the naked eye until its hull has completely disappeared from view under the supposed "curvature of the Earth," then look through a telescope, you will notice the entire ship quickly zooms back into view, hull and all, proving that the disappearance was caused by the Law of Perspective, not by a wall of curved water! This also proves that the horizon is simply the vanishing line of perspective from your point of view, NOT the alleged "curvature" of Earth.

140) Foucault's Pendulums are often quoted as proof of a rotating Earth but upon closer investigation prove the opposite. To begin with, Foucault's pendulums do not uniformly swing in any one direction. Sometimes they rotate clockwise and sometimes counter-clockwise, sometimes they fail to rotate and sometimes they rotate far too much. The behavior of the pendulum actually depends on 1) the initial force beginning its swing and, 2) the ball-and-socket joint used which most-readily facilitates circular motion over any other. The supposed rotation of the Earth is completely inconsequential and irrelevant to the pendulum's swing. If the alleged constant rotation of the Earth affected pendulums in any way, then there should be no need to manually start pendulums in motion. If the Earth's diurnal rotation caused the 360 degree uniform diurnal rotation of pendulums, then there should not exist a stationary pendulum anywhere on Earth!

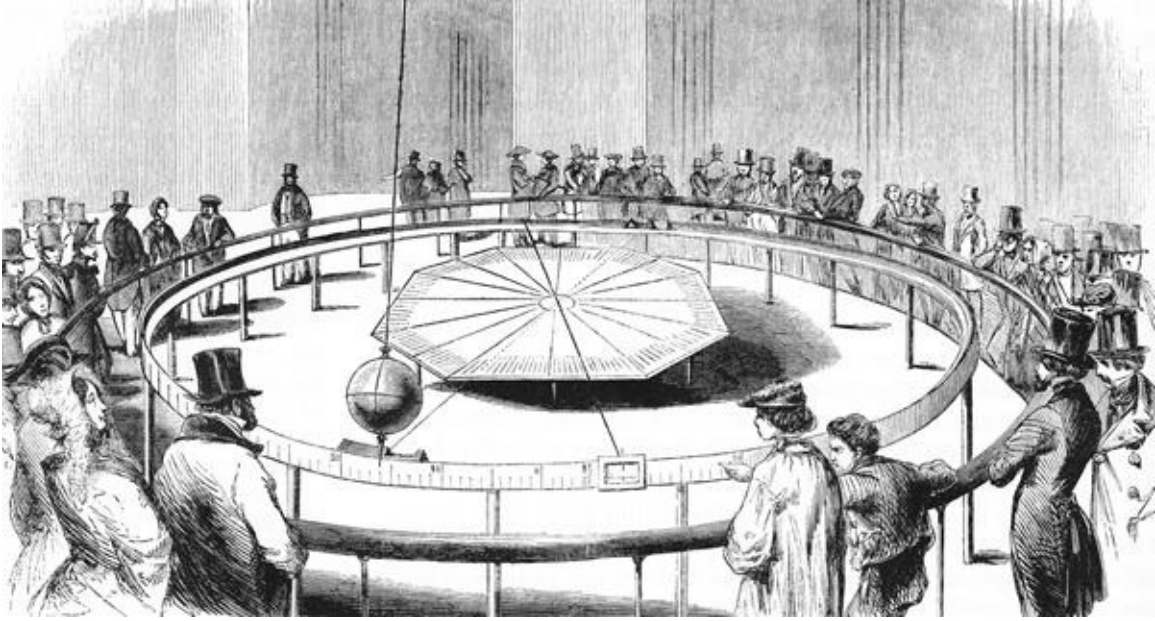

141) The “Coriolis Effect” is often said to cause sinks and toilet bowls in the Northern Hemisphere to drain spinning in one direction while in the Southern Hemisphere causing them to spin the opposite way, thus providing proof of the spinning ball-Earth. Once again, however, just like Foucault’s Pendulums spinning either which way, sinks and toilets in the Northern and Southern hemispheres do not consistently spin in any one direction! Sinks and toilets in the very same household are often found to spin opposite directions, depending entirely upon the shape of the basin and the angle of the water’s entry, not the supposed rotation of the Earth.



142) People claim that if the Earth were flat, they should be able to use a telescope and see clear across the oceans! This is absurd, however, as the air is full of precipitation especially over the oceans, and especially at the lowest, densest layer of atmosphere is NOT transparent. Picture the blurry haze over roads on hot, humid days. Even the best telescope will blur out long before you could see across an ocean. You can, however, use a telescope to zoom in MUCH more of our flat Earth than would be possible on a ball 25,000 miles in circumference.

143) People claim that if the Earth were flat, with the Sun circling over and around us, we should be able to see the Sun from everywhere all over the Earth, and there should be daylight even at night-time. Since the Sun is NOT 93 million miles away but rather just a few thousand and shining down like a spotlight, once it has moved significantly far enough away from your location it becomes invisible beyond the horizon and daylight slowly fades until it completely disappears. If the Sun were 93 million miles away and the Earth a spinning ball, the transition from daylight to night would instead be almost instantaneous as you passed the terminator line.

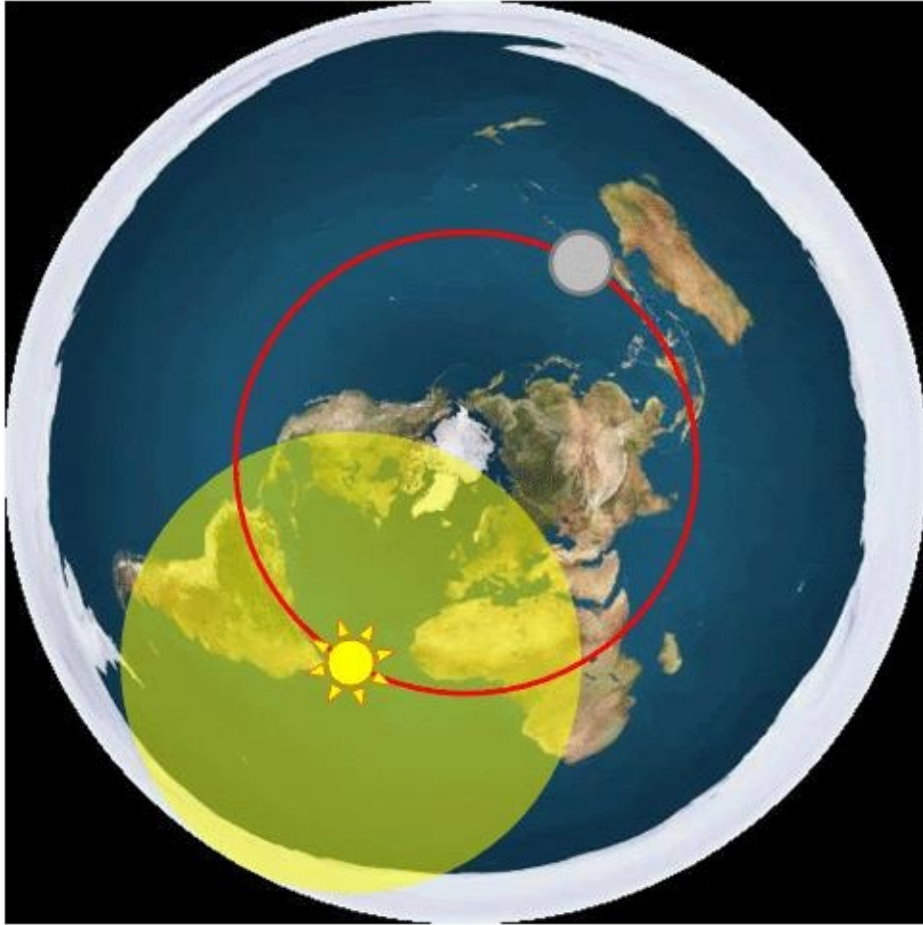

144) Pictures of the Moon appearing upside-down in the Southern hemisphere and right-side up in the North are often cited as proof of the ball-Earth, but once again, upon closer inspection, provide another proof of the flat model. In fact, time-lapse photography shows the Moon itself turns clockwise like a wheel as it circles over and around the Earth. You can find pictures of the Moon at 360 degrees of various inclination from all over the Earth simply depending on where and when the picture was taken.

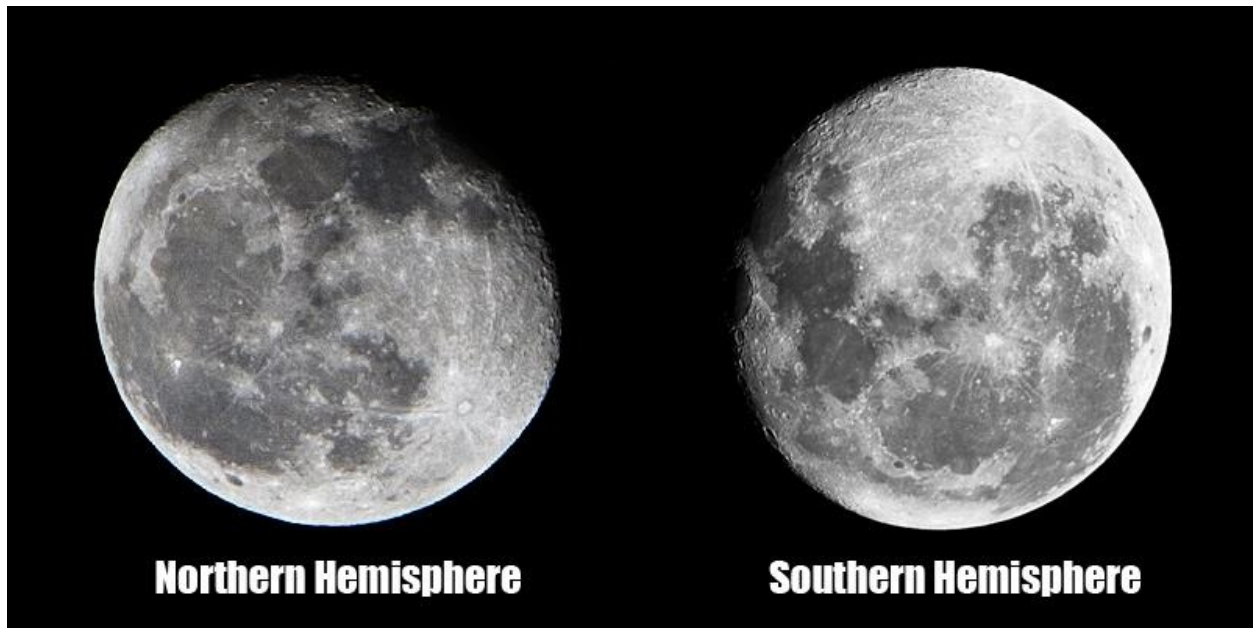

145) Heliocentrists believe the Moon is a ball, even though its appearance is clearly that of a flat luminous disc. We only ever see the same one face (albeit at various inclinations) of the Moon, yet it is claimed that there is another “dark side of the Moon” which remains hidden. NASA states the Moon spins opposite the spin of the Earth in such a perfectly synchronized way that the motions cancel each other out so we will conveniently never be able to observe the supposed dark-side of the Moon outside of their terrible fake CGI images. The fact of the matter is, however, if the Moon were a sphere, observers in Antarctica would see a different face from those at the equator, yet they do not – just the same flat face rotated at various degrees.

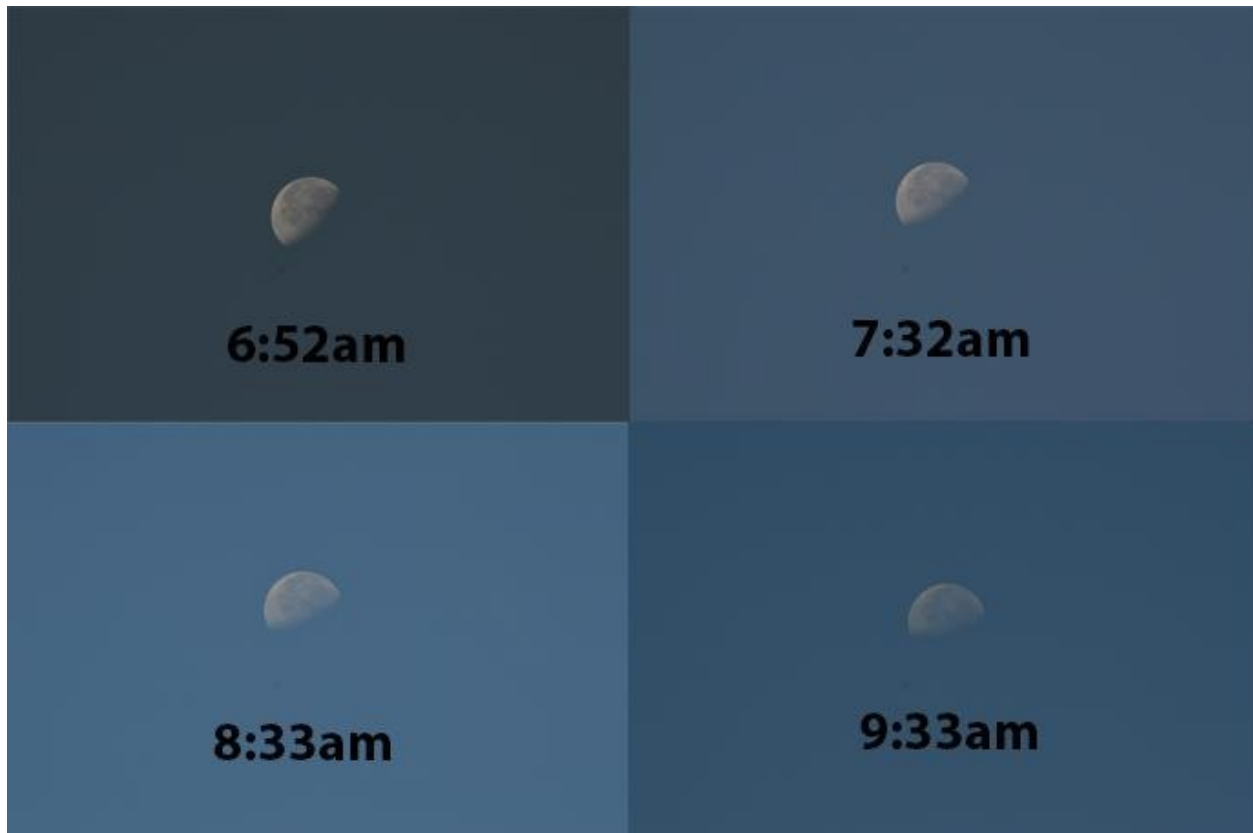

146) The ball-Earth model claims the Moon orbits around the Earth once every 28 days, yet it is plain for anyone to see that the Moon orbits around the Earth every single day! The Moon's orbit is slightly slower than the Sun's, but follows the Sun's same path from Tropic to Tropic, solstice to solstice, making a full circle over the Earth in just under 25 hours.

147) The ball-Earth model claims the Sun is precisely 400 times larger than the Moon and 400 times further away from Earth making them "falsely" appear exactly the same size. Once again, the ball model asks us to accept as coincidence something that cannot be explained other than by natural design. The Sun and the Moon occupy the same amount of space in the sky and have been measured with sextants to be of equal size and equal distance, so claiming otherwise is against our eyes, experience, experiments and common sense.

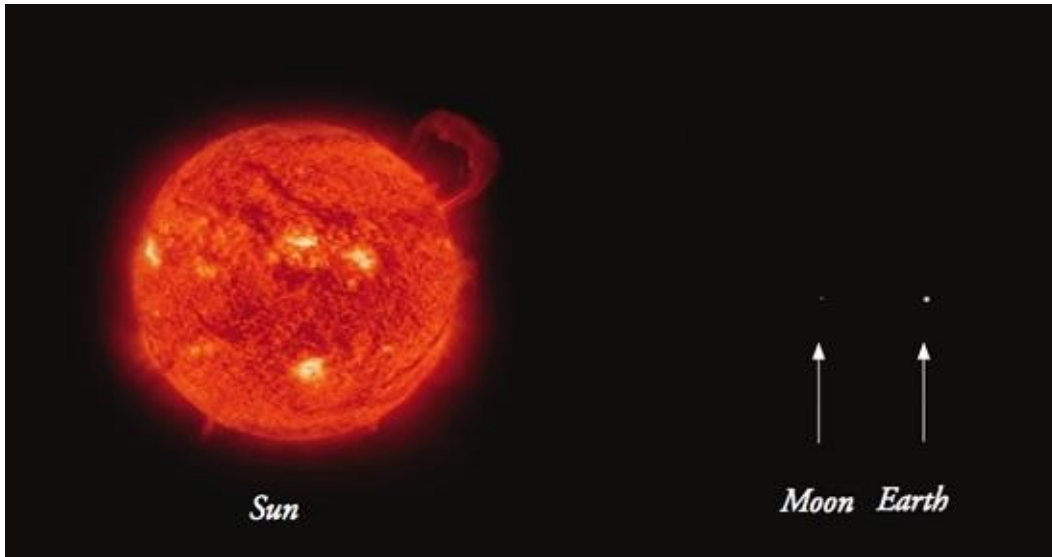

148) Quoting “[Earth Not a Globe!](#)” (page 238) by Samuel Rowbotham, “*It is found by observation that the stars come to the meridian about four minutes earlier every twenty-four hours than the sun, taking the solar time as the standard. This makes 120 minutes every thirty days, and twenty-four hours in the year. Hence all the constellations have passed before or in advance of the sun in that time. This is the simple fact as observed in nature, but the theory of rotundity and motion on axes and in an orbit has no place for it. Visible truth must be ignored, because this theory stands in the way, and prevents its votaries from understanding it.*”

149) Throughout thousands of years the same constellations have remained fixed in their same patterns without moving out of position whatsoever. If the Earth were a big ball spinning around a bigger Sun spinning around a bigger galaxy shooting off from the Biggest Bang as NASA claims, it is impossible that the constellations would remain so fixed. Based on their model, we should, in fact, have an entirely different night sky every single night and never repeat exactly the same star pattern twice.



150) If Earth were a spinning ball it would be impossible to photograph star-trail time-lapses turning perfect circles around Polaris anywhere but the North Pole. At all other vantage points the stars would be seen to travel more or less horizontally across the observer's horizon due to the alleged 1,000 mph motion beneath their feet. In reality, however, Polaris's surrounding stars can always be photographed turning perfect circles around the central star all the way down to the Tropic of Capricorn.



151) If Earth were a spinning ball revolving around the Sun it would actually be impossible for star-trail photos to show perfect circles even at the North Pole! Since the Earth is also allegedly moving 67,000 mph around the Sun, the Sun moving 500,000 mph around the Milky Way, and the entire galaxy going 670,000,000 mph, these four contradictory motions would make star-trail time-lapses all show irregular curved lines.

152) In 2003, three University Geography professors collaborated in an experiment to prove that the state of Kansas is indeed actually flatter than a pancake! Using topographical geodetic surveys covering over 80,000 square miles it was determined that Kansas has a flatness ratio of 0.9997 over the entire state while the average pancake, precisely measured using a confocal laser microscope comes in at 0.957, making Kansas thereby literally flatter than a pancake.

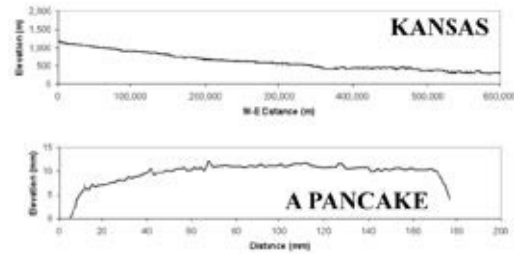

153) Quoting Reverend Thomas Milner’s [“Atlas of Physical Geography”](#) (page 19), we find that, *“Vast areas exhibit a perfectly dead level, scarcely a rise existing through 1,500 miles from the Carpathians to the Urals. South of the Baltic the country is so flat that a prevailing north wind will drive the waters of the Stattiner Haf into the mouth of the Oder, and give the river a backward flow 30 or 40 miles. The plains of Venezuela and New Granada, in South America chiefly on the left of the Orinoco, are termed Ilanos, or level fields. Often in the space of 270 square miles the surface does not vary a single foot. The Amazon only falls 12 feet in the last 700 miles of its course; the La Plata has only a descent of one thirty-third of an inch a mile.”*

154) The Felix Baumgartner Red Bull dive outside camera shows the same amount of “curvature of Earth” from surface-level to jump-height proving it to be a deceiving fish-eyed wide-angle lens, while the inside regular camera shows a perfectly flat horizon, eye level at 128,000 feet, which is only consistent with a flat plane.



155) Some people claim to have seen the curvature of the Earth out their airplane windows. The glass used in all commercial airplanes, however, is curved to remain flush with the fuselage. This creates a slight effect mixed with confirmation bias people mistake for being the alleged curvature of the Earth. In actuality, the fact that you can see the horizon at eye-level at 35,000 feet out both port/starboard windows proves the Earth is flat. If the Earth were a ball, no matter how big, the horizon would stay exactly where it was and you would have to look **DOWN** further and further to see the horizon at all. Looking straight out the window at 35,000 feet you should see nothing but "outer-space" from the port and starboard windows, as the Earth/horizon are supposed to be **BELOW** you. If they are visible at eye level outside both side windows, it's because the Earth is flat!



156) People also claim to see curvature in Go Pro or other high altitude camera footage of the horizon. While it is true that the horizon often appears convex in such footage, it just as often appears concave or flat depending on the tilt/movement of the camera. The effect is simply a distortion due to wide-angle lenses. In lens-corrected and footage taken without wide-angle technology, all amateur high-altitude horizon shots appear perfectly flat.



157) If “gravity” magically dragged the atmosphere along with the spinning ball Earth, that would mean the atmosphere near the equator would be spinning around at over 1,000 mph, the atmosphere over the mid-latitudes would be spinning around 500 mph, and gradually slower down to the poles where the atmosphere would be unaffected at 0 mph. In reality, however, the atmosphere at

every point on Earth is equally unaffected by this alleged force, as it has never been measured or calculated and proven non-existent by the ability of airplanes to fly unabated in any direction without experiencing any such atmospheric changes.

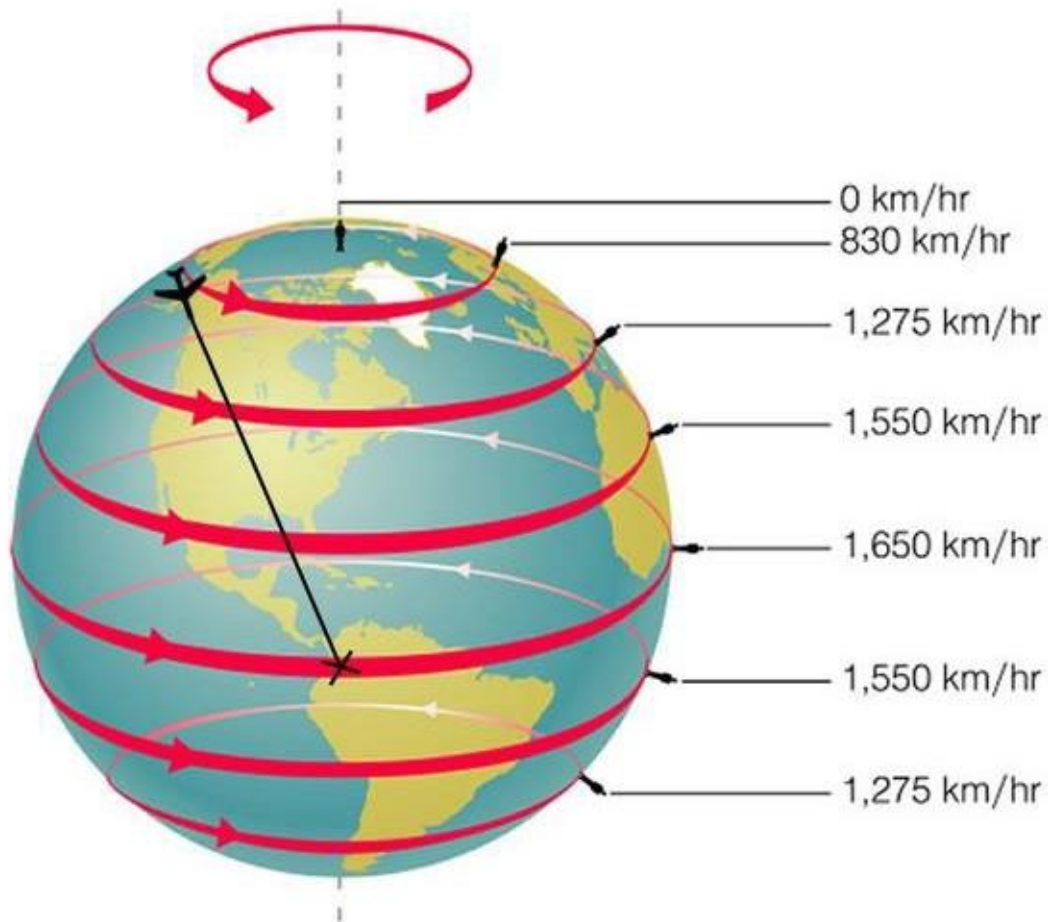

158) If “gravity” magically dragged the atmosphere along with the spinning ball Earth, that would mean the higher the altitude, the faster the spinning atmosphere would have to be turning around the center of rotation. In reality, however, if this were happening then rain and fireworks would behave entirely differently as they fell down through progressively slower and slower spinning atmosphere. Hot-air balloons would also be forced steadily faster Eastwards as they ascended through the ever increasing atmospheric speeds.

159) If there were progressively faster and faster spinning atmosphere the higher the altitude that would mean it would have to abruptly end at some key altitude where the fastest layer of gravitized spinning atmosphere meets the supposed non-gravitized non-spinning non-atmosphere of infinite vacuum space! NASA has never mentioned what altitude this impossible feat allegedly happens, but it is easily philosophically refuted by the simple fact that vacuums cannot exist connected to non-vacuums while maintaining the properties of a vacuum – not to mention, the effect such a transition would have on a rocket “space ship” would be disastrous.

160) It is impossible for rockets or any type of jet propulsion engines to work in the alleged non-atmosphere of vacuum space because without air/atmosphere to push against there is nothing to propel the vehicle forwards. Instead the rockets and shuttles would be sent spinning around their own axis uncontrollably in all directions like a gyroscope. It would be impossible to fly to the Moon or go in any direction whatsoever, especially if “gravity” were real and constantly sucking you towards the closest densest body.

161) If Earth were really a ball, there would be no reason to use rockets for flying into “outer-space” anyway because simply flying an airplane straight at any altitude for long enough should and would send you off into outer-space. To prevent their airplanes from flying tangent to the ball-Earth, pilots would have to constantly course-correct downwards, or else within just a few hours the average commercial airliner traveling 500 mph would find themselves lost in “outer-space.” The fact that this never happens, artificial horizons remain level at pilot’s desired altitudes and do NOT require constant downwards adjustments, proves the Earth is not a ball.



162) All NASA and other “space agencies” rocket launches never go straight up. Every rocket forms a parabolic curve, peaks out, and inevitably starts falling back to Earth. The rockets which are declared “successful” are those few which don’t explode or start falling too soon but make it out of range of spectator view before crashing down into restricted waters and recovered. There is no magic altitude where rockets or anything else can simply go up, up, up and then suddenly just start “free-floating” in space. This is all a science-fiction illusion created by wires, green-screens, dark pools, some permed hair and Zero-G planes.



163) NASA and other space agencies have been caught time and again with air bubbles forming and floating off in their official “outer-space” footage. Astronauts have also been caught using scuba-space-gear, kicking their legs to move, and astronaut Luca Parmitano even almost drowned when water started filling up his helmet while allegedly on a “space-walk.” It is admitted that astronauts train for their “space-walks” in under-water training facilities like NASA’s “Neutral Buoyancy Lab,” but what is obvious from their “space bubbles,” and other blunders is that all official “space-walk” footage is also fake and filmed under-water.



164) Analysis of many interior videos from the “International Space Station,” have shown the use of camera-tricks such as green-screens, harnesses and even wildly permed hair to achieve a zero-gravity type effect. Footage of astronauts seemingly floating in the zero-gravity of their “space station” is indistinguishable from “vomit comet” Zero-G airplane footage. By flying parabolic maneuvers this Zero-G floating effect can be achieved over and over again then edited together. For longer uncut shots, NASA has been caught using simple wires and green screen technology.

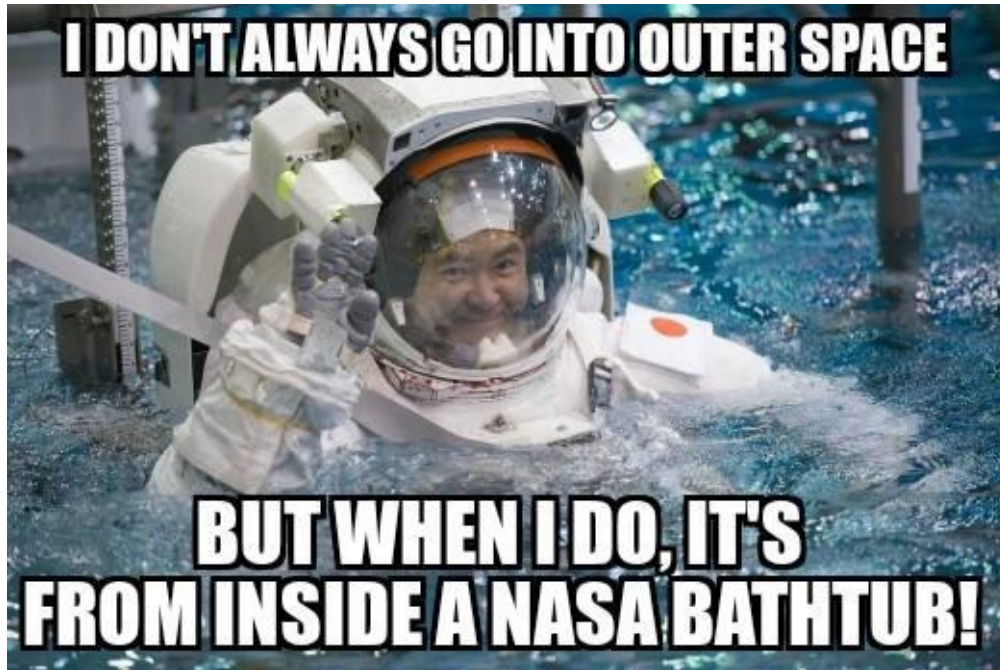

165) NASA claims one can observe the International Space Station pass by overhead proving its existence, yet analysis of the "ISS" seen through zoom cameras proves it to be some type of hologram/drone, not a physical floating space-base. As you can see in my documentary "ISS Hoax," when zooming in/out, the "ISS" dramatically and impossibly changes shape and color, displaying a prismatic rainbow effect until coming into focus much like an old television turning on/off.

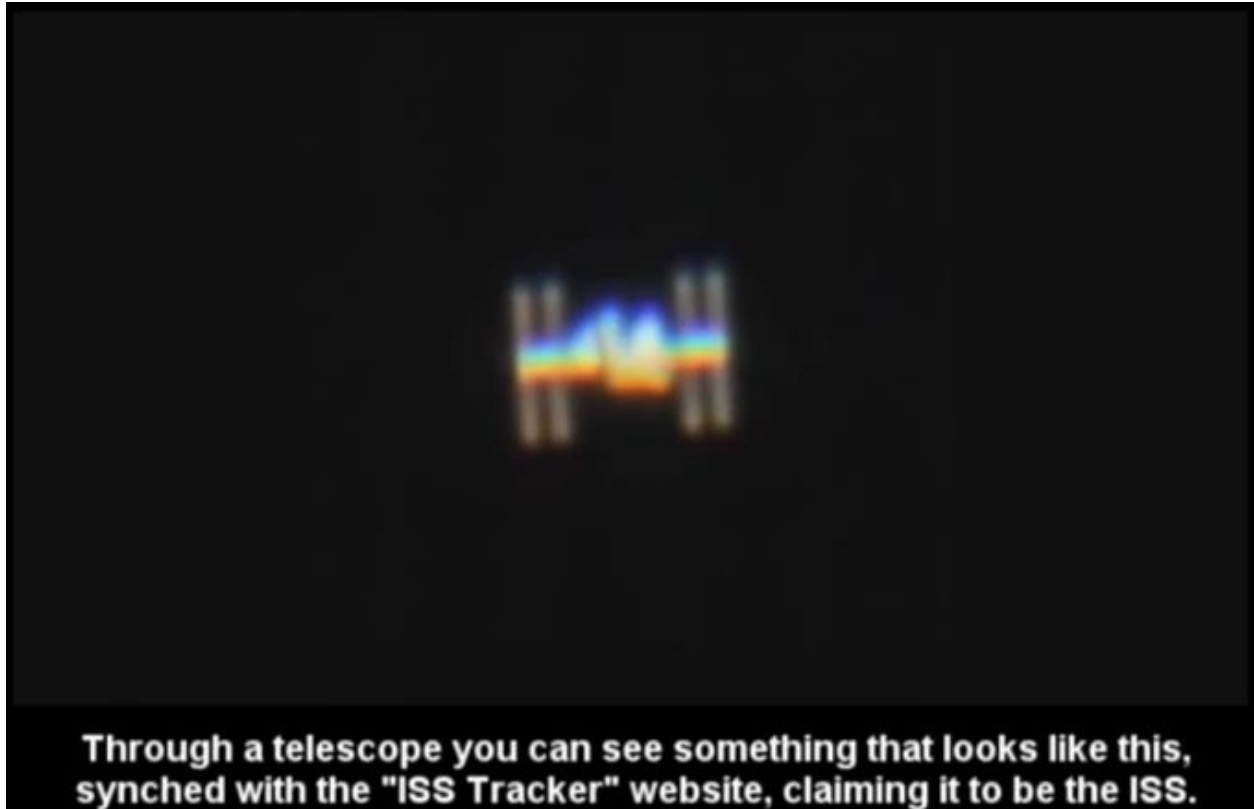

Through a telescope you can see something that looks like this, synched with the "ISS Tracker" website, claiming it to be the ISS.

[View: ISS Hoax - The International Space Station Does Not Exist!](#)

166) The “geostationary communications satellite” was first created by Freemason science-fiction writer Arthur C. Clarke and supposedly became science-fact just a decade later. Before this, radio, television, and navigation systems like LORAN and DECCA were already well-established and worked fine using only ground-based technologies. Nowadays huge fibre-optics cables connect the internet across oceans, gigantic cell towers triangulate GPS signals, and ionospheric propagation allows radio waves to be bounced all without the aid of the science-fiction best-seller known as “satellites.”



167) Satellites are allegedly floating around in the thermosphere where temperatures are claimed to be upwards of 4,530 degrees Fahrenheit. The metals used in satellites, however, such as aluminum, gold and titanium have melting points of 1,221, 1,948, and 3,034 degrees respectively, all far lower than they could possibly handle.

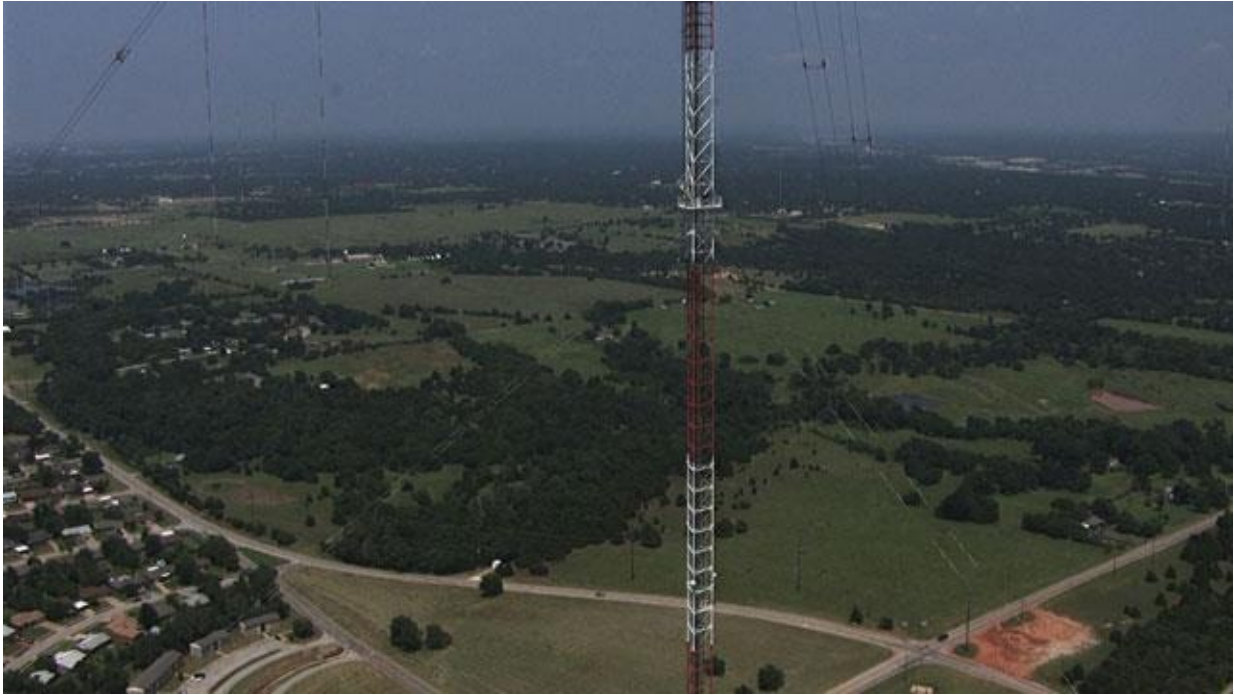

168) So-called “satellite” phones have been found to have reception problems in countries like Kazakhstan with very few cell phone towers. If the Earth were a ball with 20,000+ satellites surrounding, such blackouts should not regularly occur in any rural countryside areas.

169) So-called “satellite” TV dishes are almost always positioned at a 45 degree angle towards the nearest ground-based repeater tower. If TV antennae were actually picking up signals from satellites 100+ miles in space, most TV dishes should be pointing more or less straight up to the sky. The fact that “satellite” dishes are never pointing straight up and almost always positioned at a 45 degree angle proves they are picking up ground-based tower signals and not “outer-space satellites.”



170) People even claim to see satellites with their naked eyes, but this is ridiculous considering they are smaller than a bus and allegedly 100+ miles away; It is impossible to see anything so small that far away. Even using telescopes, no one claims to discern the shape of satellites but rather describes seeing passing moving lights, which could easily be any number of things from airplanes to drones to shooting stars or other unidentified flying objects.

171) NASA claims there are upwards of 20,000 satellites floating around Earth's upper-atmosphere sending us radio, television, GPS, and taking pictures of the planet. All these supposed satellite pictures, however, are admittedly "composite images, edited in photoshop!" They claim to receive "ribbons of imagery" from satellites which must then be spliced together to create composite images of the Earth, all of which are clearly CGI and not photographs. If Earth were truly a ball with 20,000 satellites orbiting, it would be a simple matter to mount a camera and take some real photographs. The fact that no real satellite photographs of the supposed ball Earth exist in favor of NASA's "ribbons of composite CG imagery," is further proof we are not being told the truth.

172) If you pick any cloud in the sky and watch for several minutes, two things will happen: the clouds will move and they will morph gradually changing shape. In official NASA footage of the spinning ball Earth, such as the “Galileo” time-lapse video however, clouds are constantly shown for 24+ hours at a time and not moving or morphing whatsoever! This is completely impossible, further proof that NASA produces fake CGI videos, and further evidence that Earth is not a spinning ball.



173) NASA has several alleged photographs of the ball-Earth which show several exact duplicate cloud patterns! The likelihood of having two or three clouds of the exact same shape in the same picture is as likely as finding two or three people with exactly the same fingerprints. In fact it is solid proof that the clouds were copied and pasted in a computer program and that such pictures showing a ball-shaped Earth are fakes.

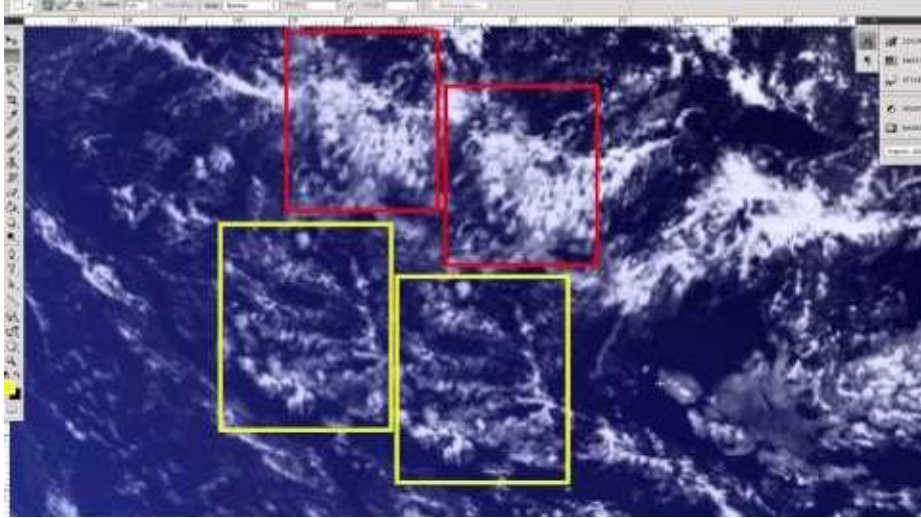

174) NASA graphics artists have placed things like faces, dragons, and even the word “SEX” into cloud patterns over their various ball-Earth pictures. Their recent 2015 Pluto pictures even clearly have a picture of Disney’s “Pluto” the dog layered into the background. Such blatant fraud goes unnoticed by the hypnotized masses, but provides further proof of the illegitimacy of NASA and their spinning ball planet mythos.



175) Professional photo-analysts have dissected several NASA images of the ball-Earth and found undeniable proof of computer editing. For example, images of the Earth allegedly taken from the Moon have proven to be copied and pasted in, as evidenced by rectangular cuts found in the black background around the “Earth” by adjusting brightness and contrast levels. If they were truly on the Moon and Earth was truly a ball, there would be no need to fake such pictures.

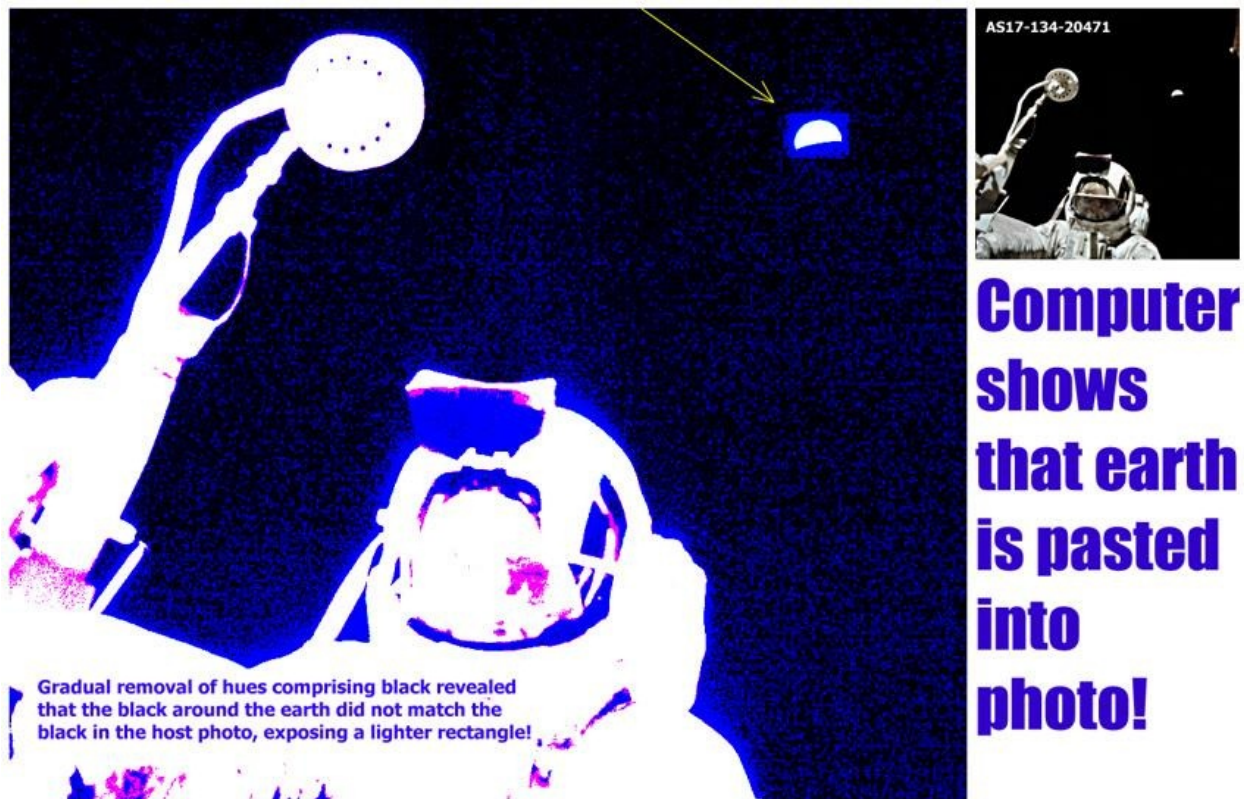

176) When NASA’s images of the ball-Earth are compared with one another the coloration of the land/oceans and relative size of the continents are consistently so drastically different from one another as to prove beyond any reasonable doubt that the pictures are all fake.

How Big is America....



2007



2012

“Photos” courtesy of NASA.

177) In the documentary “A Funny Thing Happened on the Way to the Moon,” you can watch official leaked NASA footage showing Apollo 11 astronauts Buzz Aldrin, Neil Armstrong and Michael Collins, for almost an hour, using transparencies and camera-tricks to fake shots of a round Earth! They communicate over audio with control in Houston about how to accurately stage the shot, and someone keeps prompting them on how to effectively manipulate the camera to achieve the desired effect. First, they blacked out all the windows except for a downward facing circular one, which they aimed the camera towards from several feet away. This created the illusion of a ball-shaped Earth surrounded by the blackness of space, when in fact it was simply a round window in their dark cabin. Neil Armstrong claimed at this point to be 130,000 miles from Earth, half-way to the Moon, but when camera-tricks were finished

the viewer could see for themselves the astro-nots were not more than a couple dozen miles above the Earth's surface, likely flying in a high-altitude plane!

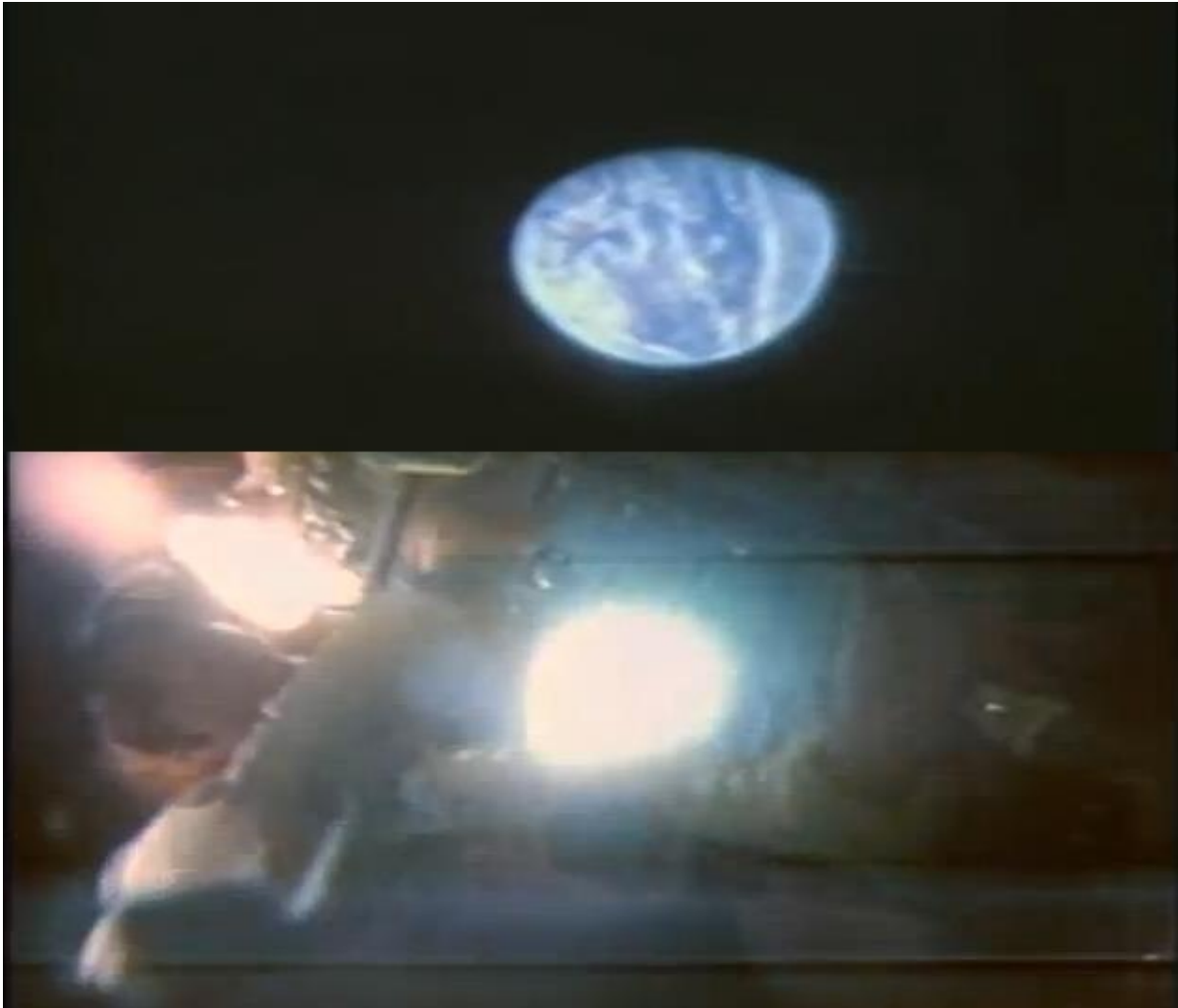

[View: A Funny Thing Happened on the Way to the Moon](#)

178) People claim Google Earth somehow proves the ball model without realizing that Google Earth is simply a composite program of images taken from high-altitude planes and street-level car-cameras superimposed onto a CGI model of a ball Earth. The same could be just as easily modeled onto a square Earth or any other shape and therefore cannot be used as proof of Earth's rotundity.



179) If the Earth were constantly spinning Eastwards 1,000 mph then airplane flight durations going Eastwards vs. Westwards should be significantly different. If the average commercial airliner travels 500 mph, it follows that Westbound equatorial flights should reach their destination at approximately thrice the speed as their Eastbound return flights. In reality, however, the differences in East/Westbound flight durations usually amount to a matter of minutes, and nothing near what would occur on a 1,000 mph spinning ball Earth.

180) The spinning ball model dictates that the Earth and atmosphere would be moving together at approximately 500 mph at the mid-latitudes where an LA to NYC flight takes place. The average commercial airliner traveling 500 mph takes 5.5 hours traveling East with the alleged rotation of the Earth, so the return flight West should take only 2.75 hours, but in fact we find the average NYC to LA flight takes 6 hours, a flight time totally inconsistent with the spinning ball model.

181) Flights Eastwards with the alleged spin of the ball-Earth from Tokyo to LA

take an average of 10.5 hours, therefore the return flights Westwards against the alleged spin should take an average of 5.25 hours, but in actual fact take an average of 11.5 hours, another flight time totally inconsistent with the spinning ball model.

182) Flights Eastwards with the alleged spin of the ball-Earth from NYC to London take an average of 7 hours, therefore the return flights Westwards against the alleged spin should take an average of 3.5 hours, but in actual fact take an average of 7.5 hours, a flight time totally inconsistent with the spinning ball model.

183) Flights Eastwards from Chicago to Boston with the alleged spin of the ball-Earth take an average of 2.25 hours, therefore the return flights Westwards against the alleged spin should take an average of just over an hour, but in actual fact take an average of 2.75 hours, once again, completely inconsistent with the spinning ball model.

184) Flights Eastwards from Paris to Rome with the alleged spin of the ball-Earth take an average of 2 hours, therefore the return flights Westwards against the alleged spin should take an average of 1 hour, but in actual fact have an average flight duration of 2 hours 10 minutes, a flight time totally inconsistent with the spinning ball model.



185) We are told that the Earth and atmosphere spin together at such a perfect uniform velocity that no one in history has ever seen, heard, felt or measured the supposed 1,000 mph movement. This is then often compared to traveling in a car at uniform velocity, where we only feel the movement during acceleration or deceleration. In reality, however, even with eyes closed, windows up, over smooth tar in a luxury car at a mere uniform 50 mph, the movement absolutely can be felt! At 20 times this speed, Earth's imaginary 1,000 mph spin would most certainly be noticeable, felt, seen and heard by all.

186) People sensitive to motion sickness feel distinct unease and physical discomfort from motion as slight as an elevator or a train ride. This means that the 1,000 mph alleged uniform spin of the Earth has no effect on such people, but add an extra 50 mph uniform velocity of a car and their stomach starts

turning knots. The idea that motion sickness is nowhere apparent in anyone at 1,000 mph, but suddenly comes about at 1,050 mph is ridiculous and proves the Earth is not in motion whatsoever.

187) The second law of thermodynamics, otherwise known as the law of entropy, along with the fundamental principles of friction/resistance determine the impossibility of Earth being a uniformly spinning ball. Over time, the spinning ball Earth would experience measurable amounts of drag constantly slowing the spin and lengthening the amount of hours per day. As not the slightest such change has ever been observed in all of recorded history it is absurd to assume the Earth has ever moved an inch.



entropy

188) Over the years NASA has twice changed their story regarding the shape of the Earth. At first they maintained Earth was a perfect sphere, which later changed to an “oblate spheroid” flattened at the poles, and then changed again to being “pear-shaped” as the Southern hemisphere allegedly bulges out as well. Unfortunately for NASA, however, none of their official pictures show an oblate spheroid or pear-shaped Earth! All their pictures, contrary to their words, show a spherical (and clearly CGI fake) Earth.

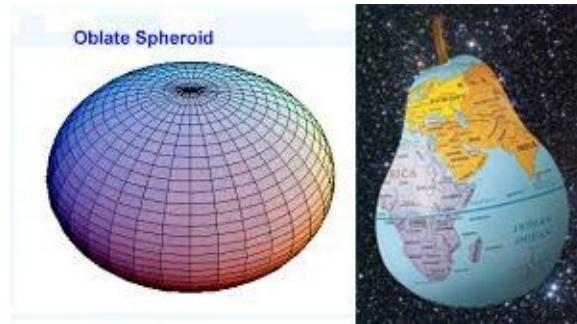

189) The Bible, Koran, Srimad Bhagavatam, and many other holy books describe and purport the existence of a geocentric, stationary flat Earth. For example, 1 Chronicles 16:30 and Psalm 96:10 both read, “*He has fixed the earth firm, immovable.*” And Psalm 93:1 says, “*The world also is established, that it cannot be moved.*” The Bible also repeatedly affirms that the Earth is “outstretched” as a plane, with the outstretched heavens everywhere above (not all around) giving a scriptural proof the Earth is not a spinning ball.

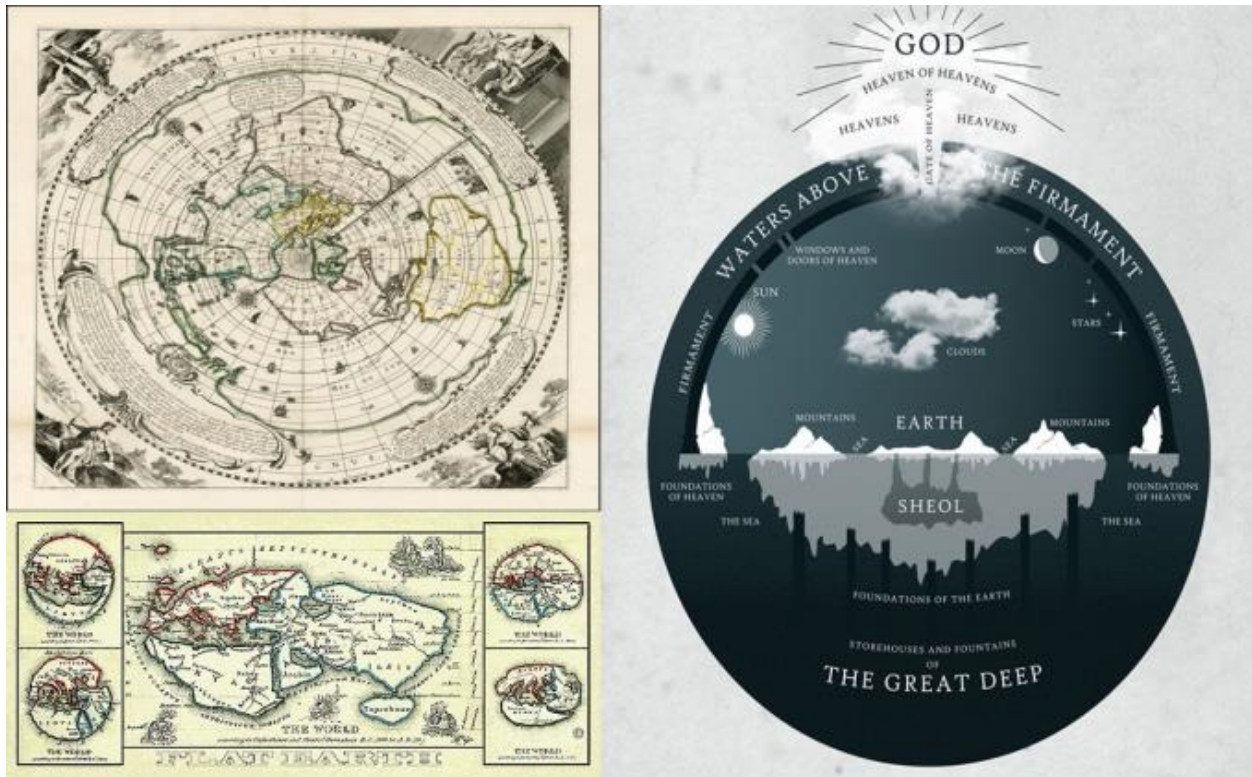

190) Cultures the world over throughout history have all described and purported the existence of a geocentric, stationary flat Earth. Egyptians, Indians,

Mayans, Chinese, Native Americans and literally every ancient civilization on Earth had a geocentric flatEarth cosmology. Before Pythagoras, the idea of a spinning ball-Earth was non-existent and even after Pythagoras it remained an obscure minority view until 2,000 years later when Copernicus began reviving the heliocentric theory.

191) From Pythagoras to Copernicus, Galileo and Newton, to modern astronauts like Aldrin, Armstrong and Collins, to director of NASA and Grand Commander of the 33rd degree C. Fred Kleinknecht, the founding fathers of the spinning ball mythos have all been Freemasons! The fact that so many members of this, the largest and oldest secret society in existence have all been co-conspirators bringing about this literal “planetary revolution” is beyond the possibility of coincidence and provides proof of organized collusion in creating and maintaining this multi-generational deception.



192) Quoting “[Terra Firma](#)” (page 10) by David Wardlaw Scott, “*The system of the Universe, as taught by Modern Astronomers, being founded entirely on theory, for the truth of which they are unable to advance one single real proof, they have entrenched themselves in a conspiracy of silence, and decline to*

answer any objections which may be made to their hypotheses ... Copernicus himself, who revived the theory of the heathen philosopher Pythagoras, and his great exponent Sir Isaac Newton, confessed that their system of a revolving Earth was only a possibility, and could not be proved by facts. It is only their followers who have decorated it with the name of an ‘exact science,’ yea, according to them, ‘the most exact of all the sciences.’ Yet one Astronomer Royal for England once said, speaking of the motion of the whole Solar system: ‘The matter is left in a most delightful state of uncertainty, and I shall be very glad if any one can help me out of it.’ What a very sad position for an ‘exact science’ to be in is this!”

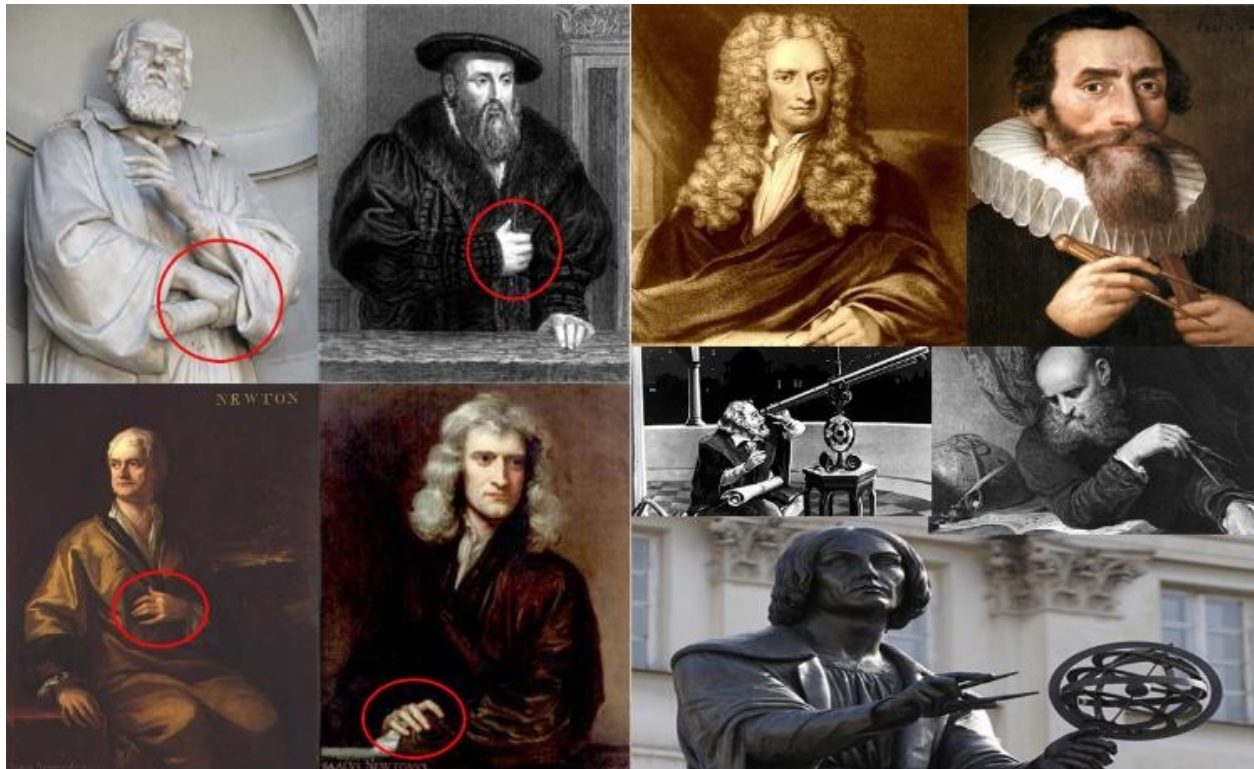

193) No child or un-indoctrinated man in their right-mind would ever conclude or even conceive given to their own devices, based on their own personal observations, that the Earth was a spinning ball revolving around the Sun! Such imaginative theories nowhere present in anyone’s daily experience require and have required massive amounts of constant propaganda to uphold the illusion.

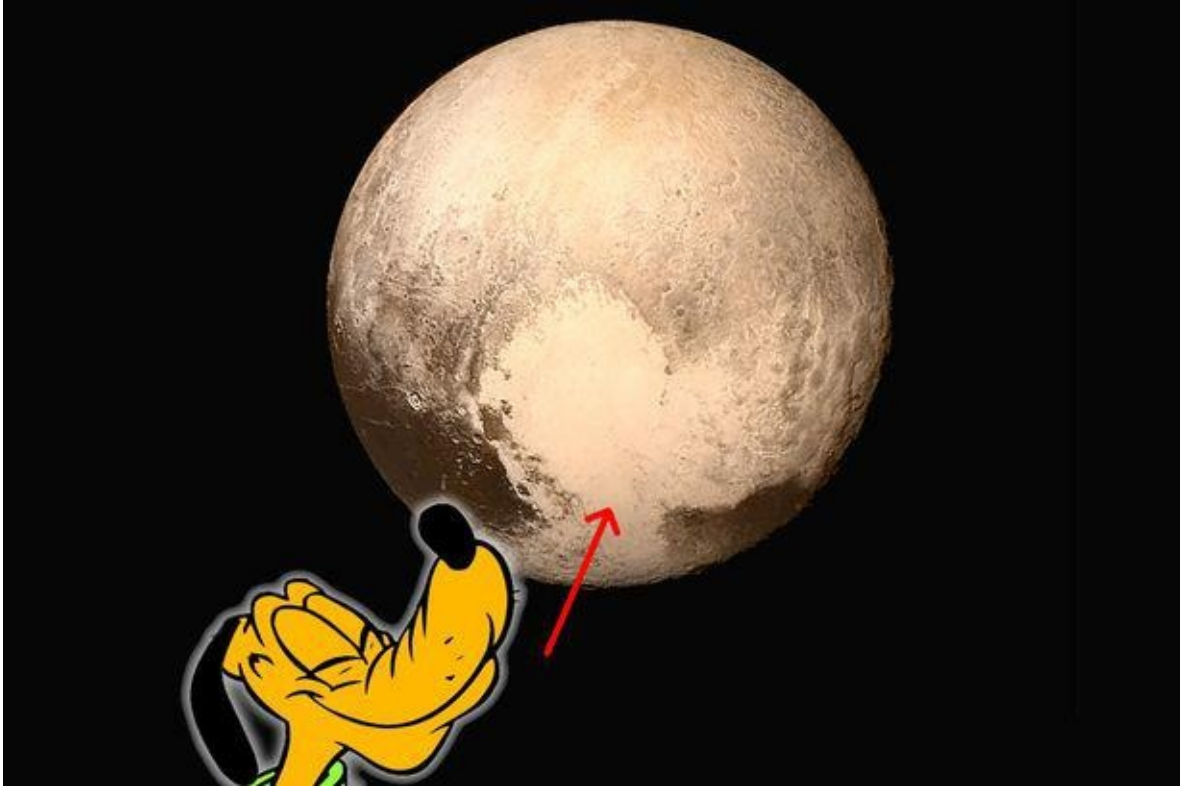

194) From David Wardlaw Scott (page 1), *“I remember being taught when a boy, that the Earth was a great ball, revolving at a very rapid rate around the Sun, and, when I expressed to my teacher my fears that the waters of the oceans would tumble off, I was told that they were prevented from doing so by Newton’s great law of Gravitation, which kept everything in its proper place. I presume that my countenance must have shown some signs of incredulity, for my teacher immediately added - I can show you a direct proof of this; a man can whirl around his head a pail filled with water without its being spilt, and so, in like manner, can the oceans be carried round the Sun without losing a drop. As this illustration was evidently intended to settle the matter, I then said no more upon the subject. Had such been proposed to me afterwards as a man, I would have answered somewhat as follows - Sir, I beg to say that the illustration you have given of a man whirling a pail of water round his head, and the oceans revolving round the Sun, does not in any degree confirm your argument, because the water in the two cases is placed under entirely different circumstances, but, to be of*

any value, the conditions in each case must be the same, which here they are not. The pail is a hollow vessel which holds the water inside it, whereas, according to your teaching, the Earth is a ball, with a continuous curvature outside, which, in agreement with the laws of nature, could not retain any water.”

195) Astronomers say the magical magnetism of gravity is what keeps all the oceans of the world stuck to the ball-Earth. They claim that because the Earth is so massive, by virtue of this mass it creates a magic force able to hold people, oceans and atmosphere tightly clung to the underside of the spinning ball. Unfortunately, however, they cannot provide any practical example of this on a scale smaller than the planetary. A spinning wet tennis ball, for instance, has the exact opposite effect of the supposed ball-Earth! Any water poured over it simply falls off the sides, and giving it a spin results in water flying off 360 degrees like a dog shaking after a bath. Astronomers concede the wet tennis ball example displays the opposite effect of their supposed ball-Earth, but claim that at some unknown mass, the magic adhesive properties of gravity suddenly kick in allowing the spinning wet tennis ball-Earth to keep every drop of “gravitized” water stuck to the surface. When such an unproven theory goes against all experiments, experience and common sense, it is high time to drop the theory.



196) Quoting Marshall Hall (“[A Small, Young Universe After All!](#)”), “In short, the sun, moon, and stars are actually doing precisely what everyone throughout all history has seen them do. We do not believe what our eyes tell us because we have been taught a counterfeit system which demands that we believe what has never been confirmed by observation or experiment. That counterfeit system demands that the Earth rotate on an 'axis' every 24 hours at a speed of over 1,000 MPH at the equator. No one has ever, ever, ever seen or felt such movement (nor seen or felt the 67,000 MPH speed of the Earth's alleged orbit around the sun or its 500,000 MPH alleged speed around a galaxy or its retreat from an alleged 'Big Bang' at over 670,000,000 MPH!). Remember, no experiment has ever shown the earth to be moving. Add to that the fact that the alleged rotational speed we've all been taught as scientific fact **MUST** decrease every inch or mile one goes north or south of the equator, and it becomes readily apparent that such things as accurate aerial bombing in WWII (down a chimney

from 25,000 feet with a plane going any direction at high speed) would have been impossible if calculated on an earth moving below at several hundred MPH and changing constantly with the latitude.”



197) Some people claim there is no motive for such a grand-scale deception and that flat or a ball makes no difference. By removing Earth from the motionless center of the Universe, these Masons have moved us physically and metaphysically from a place of supreme importance to one of complete nihilistic indifference. If the Earth is the center of the Universe, then the ideas of God, creation, and a purpose for human existence are resplendent. But if the Earth is just one of billions of planets revolving around billions of stars in billions of galaxies, then the ideas of God, creation, and a specific purpose for Earth and human existence become highly implausible. By surreptitiously indoctrinating us into their scientific materialist Sun-worship, not only do we lose faith in anything beyond the material, we gain absolute faith in materiality, superficiality, status, selfishness, hedonism and consumerism. If there is no God, and everyone is just an accident, then all that really matters is me, me, me. They have turned Madonna, the Mother of God, into a material girl living in a material world. Their rich, powerful corporations with slick Sun-cult logos sell us idols to

worship, slowly taking over the world while we tacitly believe their “science,” vote for their politicians, buy their products, listen to their music, and watch their movies, sacrificing our souls at the altar of materialism. To quote Morris Kline ([“Mathematical Thought From Ancient to Modern Times”](#), page 246), *“The heliocentric theory, by putting the sun at the center of the universe ... made man appear to be just one of a possible host of wanderers drifting through a cold sky. It seemed less likely that he was born to live gloriously and to attain paradise upon his death. Less likely, too, was it that he was the object of God’s ministrations.”*

198) Some say the idea of an inter-generational worldwide conspiracy to delude the masses sounds implausible or unrealistic, but these people need only familiarize themselves with the works and writings of Freemasons themselves, for example John Robison who exposed this in his 1798 book, [“Proofs of a Conspiracy Against All the Religions and Governments of Europe Carried Out in the Secret Meetings of the Freemasons, Illuminati and Reading Societies.”](#) Supreme Commander of the 33rd degree Albert Pike was quite forth-coming in several letters regarding the Masons ultimate goal of world domination, and in the Zionist “Protocols of the Learned Elders of Zion” the exact plan by which this would be and has been carried out is completely disclosed.



199) From [“Foundations of Many Generations”](#) (page 8) by E. Eschini, *“The one thing the fable of the revolving Earth has done, it has shown the terrible power of a lie, a lie has the power to make a man a mental slave, so that he dares not*

back the evidence of his own senses. To deny the plain and obvious movement of the Sun he sees before him. When he feels himself standing on an Earth utterly devoid of motion, at the suggestion of someone else he is prepared to accept that he is spinning furiously round. When he sees a bird flying, and gaining over the ground, he is prepared to believe that the ground is really travelling a great number of times faster than the bird, finally, in order to uphold the imagination of a madman, he is prepared to accuse his Maker of forming him a sensiferous lie.”

200) And finally, from Dr. Rowbotham (“[Earth Not a Globe!](#)”, page 257), “*Thus we see that this Newtonian philosophy is devoid of consistency; its details are the result of an entire violation of the laws of legitimate reasoning, and all its premises are assumed. It is, in fact, nothing more than assumption upon assumption, and the conclusions derived therefrom are willfully considered as things proved, and to be employed as truths to substantiate the first and fundamental assumptions. Such a ‘juggle and jumble’ of fancies and falsehoods extended and intensified as in theoretical astronomy is calculated to make the unprejudiced inquirer revolt with horror from the terrible conjuration which has been practised upon him; to sternly resolve to resist its further progress; to endeavour to over-throw the entire edifice, and to bury in its ruins the false honours which have been associated with its fabricators, and which still attach to its devotees. For the learning, the patience, the perseverance and devotion for which they have ever been examples, honour and applause need not be withheld; but their false reasoning, the advantages they have taken of the general ignorance of mankind in respect to astronomical subjects, and the unfounded theories they have advanced and defended, cannot be otherwise than regretted, and ought to be by every possible means uprooted.”*



For more information about our Flat Earth read
"The Flat Earth Conspiracy" by Eric Dubay
and visit:

<http://www.AtlanteanConspiracy.com>

<http://www.ifers.boards.net>

